

3161

HALL-EFFECT SWITCH FOR 2-WIRE APPLICATIONS

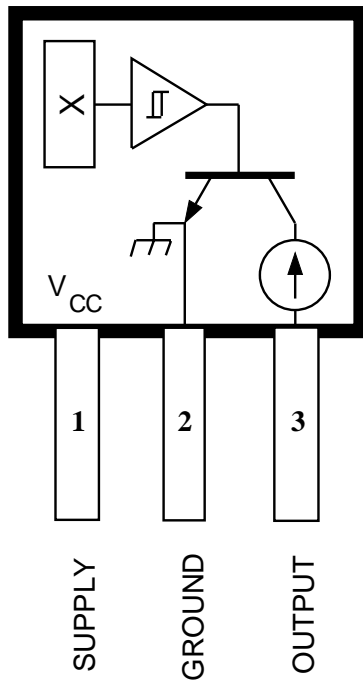

Dwg. PH-003-3

Pinning is shown viewed from branded side.

ABSOLUTE MAXIMUM RATINGS at $T_A = +25^\circ\text{C}$

Supply Voltage, V_{CC}	
Continuous	28 V
Surge ($t_w \leq 100$ ms)	40 V
Reverse Battery Voltage, V_{RCC}	
Continuous	-25 V
Surge ($t_w \leq 100$ ms)	-40 V
Magnetic Flux Density, B	Unlimited
Output OFF Voltage, V_{OUT}	28 V
Operating Temperature Range,	
T_A	-40°C to +85°C
Storage Temperature Range,	
T_S	-65°C to +170°C

This Hall-effect switch is a monolithic integrated circuit designed to operate continuously over extended temperatures to +85°C. The unipolar switching characteristic makes this device ideal for use with a simple bar or rod magnet. The A3161ELT and A3161EUA are identical except for package.

Each device includes a voltage regulator for operation with supply voltages of 3.5 to 25 volts, reverse battery protection diode, quadratic Hall-voltage generator, temperature compensation circuitry, small-signal amplifier, Schmitt trigger, and a constant-current open-collector output. Noise radiation is limited by control of the output current slew rate.

Two package styles provide a magnetically optimized package for most applications. Suffix 'LT' is a miniature SOT-89/TO-243AA transistor package for surface-mount applications; suffix 'UA' is a three-lead ultra-mini SIP for through-hole mounting.

FEATURES and BENEFITS

- Internal Current Regulator for 2-Wire Operation
- Output Slew Rate Controlled
- 3.5 V to 25 V Operation ... Needs Only An Unregulated Supply
- Reverse Battery Protection
- Excellent Temp. Stability
- Activate with Small, Commercially Available Permanent Magnets
- Small Size
- Solid-State Reliability ... No Moving Parts
- Resistant to Physical Stress

Always order by complete part number, e.g., **A3161ELT**.

3161

HALL-EFFECT SWITCH FOR 2-WIRE APPLICATIONS

ELECTRICAL CHARACTERISTICS over operating voltage and temperature ranges.

Characteristic	Symbol	Test Conditions	Limits			
			Min.	Typ.	Max.	Units
Supply Voltage	V_{CC}	Operating	3.5	—	25	V
Load Current (2-wire application)	$I_{OUT} + I_{CC}$	$3.5\text{ V} \leq V_{OUT} < 12\text{ V}, B < B_{RP}$	12	15	17	mA
		$V_{OUT} \geq 12\text{ V}, B < B_{RP}$	12	15	19	mA
		$B > B_{OP}$	—	3.5	5.0	mA
Output Current	I_{OUT}	$B < B_{RP}$	—	12	—	mA
	I_{OFF}	$V_{OUT} = 24\text{ V}, B > B_{OP}$	—	<1.0	10	μA
Output Saturation Voltage	V_{OUT}	$I_{OUT} = 5\text{ mA}, B < B_{RP}$	—	0.9	1.5	V
Output Slew Rate	di/dt	$C_L = 20\text{ pF}$	—	7.0	20	mA/ μs
Output Settling Time	t_{sd}	$C_L = 20\text{ pF}$	—	—	20	μs

MAGNETIC CHARACTERISTICS over operating supply voltage range.

Characteristic	Symbol	Limits						Units
		At $T_A = +25^\circ\text{C}$			Over Oper. Temp. Range			
		Min.	Typ.	Max.	Min.	Typ.	Max.	
Operate Point (output turns OFF)	B_{OP}	—	130	160	—	130	160	G
Release Point (output turns ON)	B_{RP}	30	110	—	30	110	—	G
Hysteresis ($B_{OP} - B_{RP}$)	B_{hys}	5.0	20	—	5.0	20	80	G

NOTE: Typical values are at $T_A = +25^\circ\text{C}$ and $V_{CC} = 12\text{ V}$.

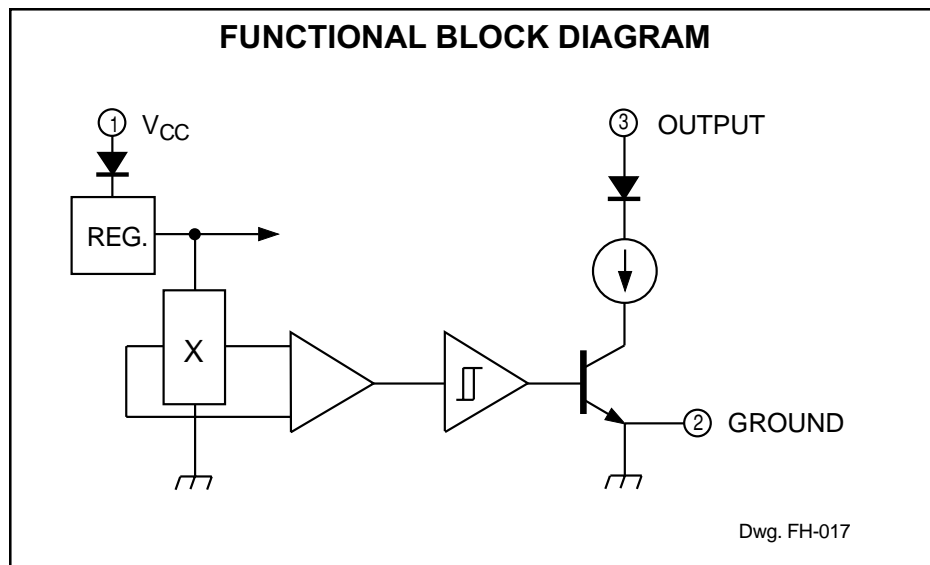

3161 HALL-EFFECT SWITCH FOR 2-WIRE APPLICATIONS

TYPICAL OPERATING CHARACTERISTICS

SWITCH POINTS

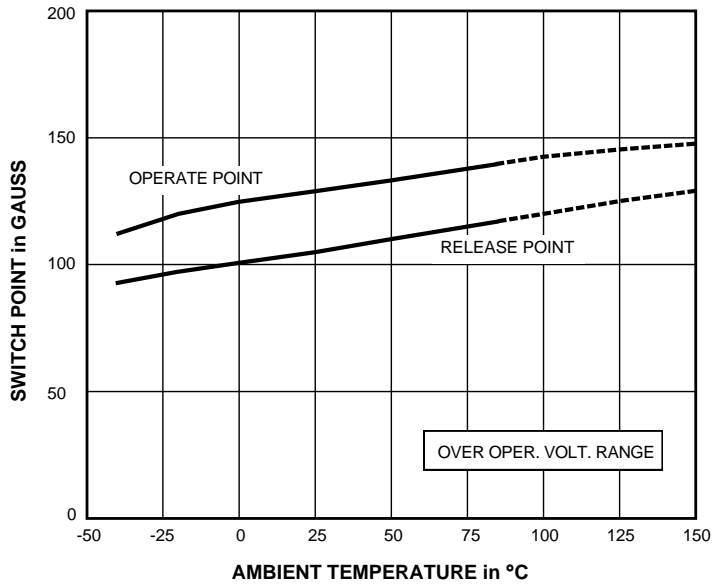

Dwg. GH-044-1

TOTAL SUPPLY CURRENT

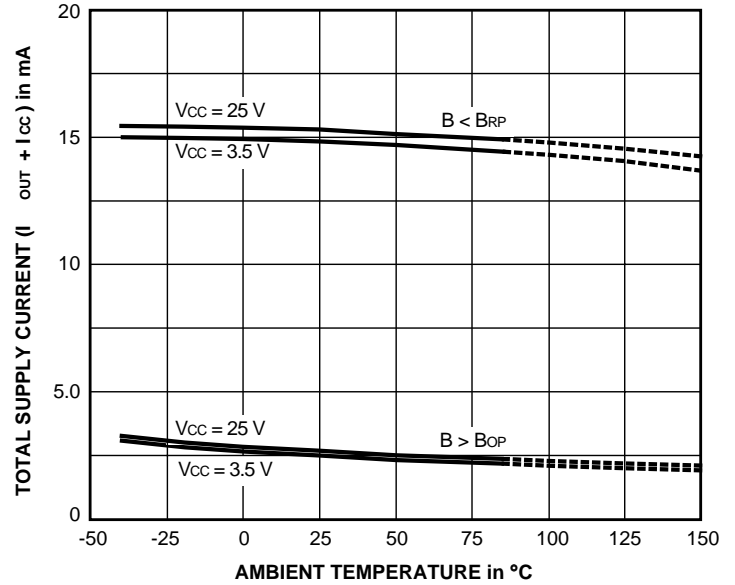

Dwg. GH-028-4

OUTPUT SATURATION VOLTAGE

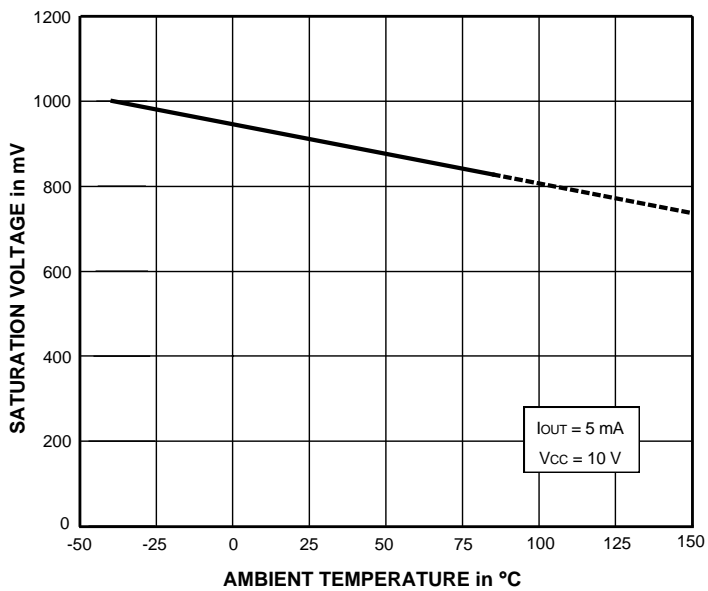

Dwg. GH-029-3

SAFE OPERATING AREA

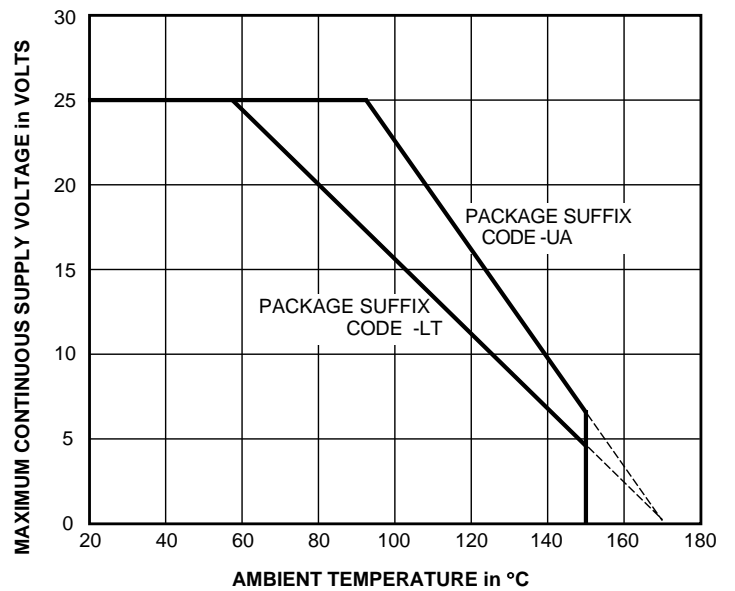

Dwg. GH-068

3161 HALL-EFFECT SWITCH FOR 2-WIRE APPLICATIONS

SENSOR LOCATIONS

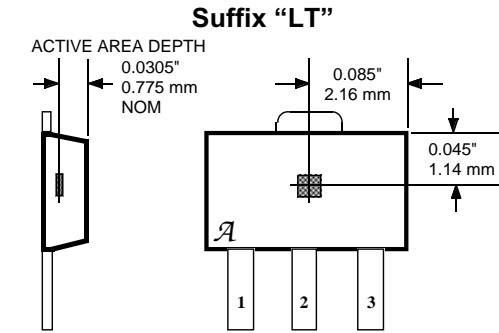

Dwg. MH-008-7A

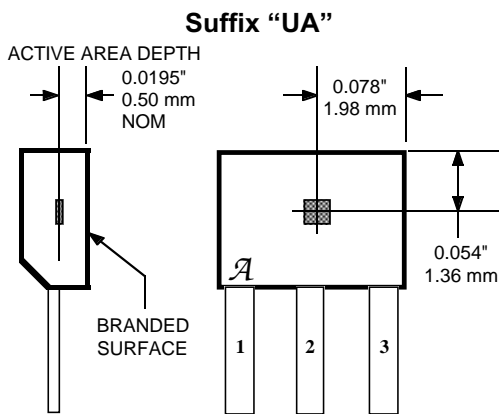

Dwg. MH-011-8A

OPERATION

The output of these devices (pin 3) switches OFF when the magnetic field at the Hall sensor exceeds the operate point threshold (B_{OP}). When the magnetic field is reduced to below the release point threshold (B_{RP}), the device output switches ON. The difference in the magnetic operate and release points is called the hysteresis (B_{hys}) of the device. This built-in hysteresis allows clean switching of the output even in the presence of external mechanical vibration and electrical noise.

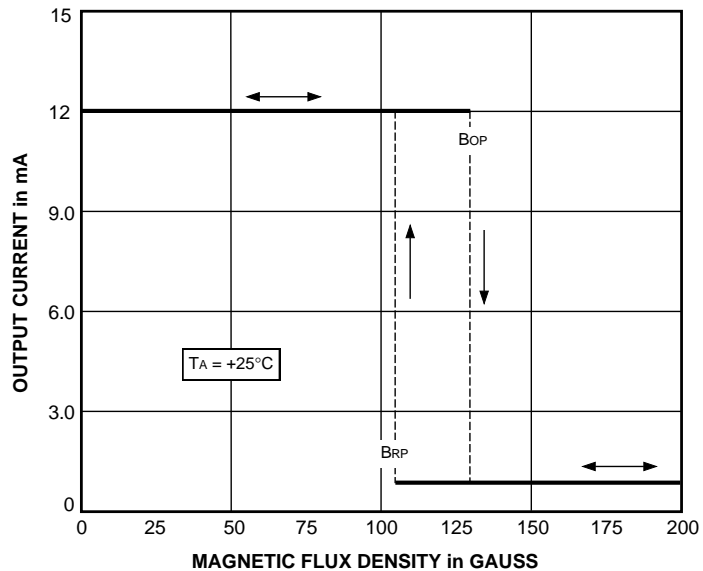

Dwg. GH-007-1

APPLICATIONS INFORMATION

These devices are normally operated in a 2-wire mode, where the supply terminal and the output terminal are tied together. An external comparator detects the change in total supply current by the addition (output off, $B > B_{OP}$) or subtraction (output on, $B < B_{RP}$) of I_{OUT} .

Hall effect applications information is available in the "Hall-Effect IC Applications Guide", which can be found in the latest issue of the *Allegro MicroSystems Electronic Data Book*, AMS-702 or *Application Note 27701*, or at www.allegromicro.com.

TYPICAL 2-WIRE APPLICATION

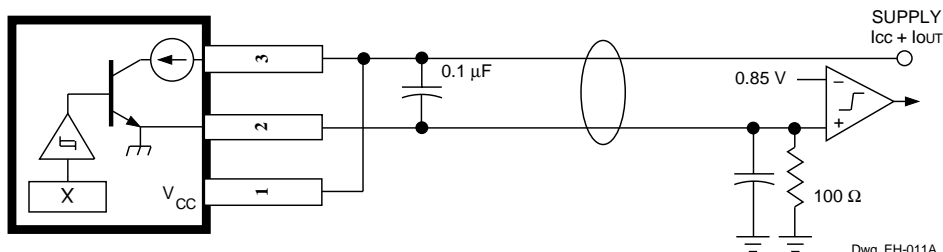

Dwg. EH-011A

3161 HALL-EFFECT SWITCH FOR 2-WIRE APPLICATIONS

PACKAGE DESIGNATOR 'LT' (SOT89/TO-243AA)

Dimensions in Inches
(for reference only)

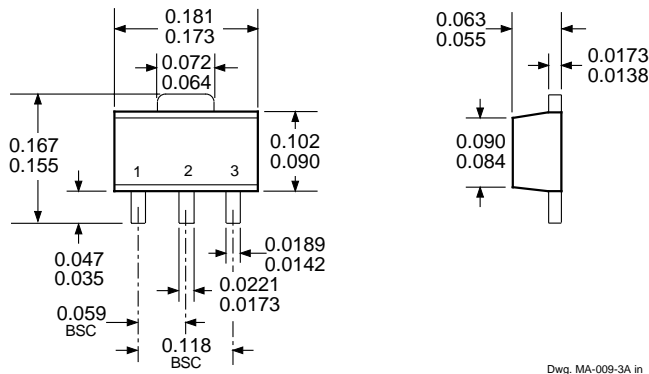

Dimensions in Millimeters
(controlling dimensions)

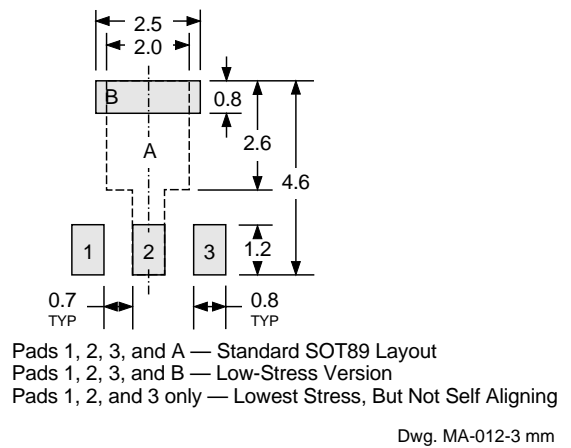
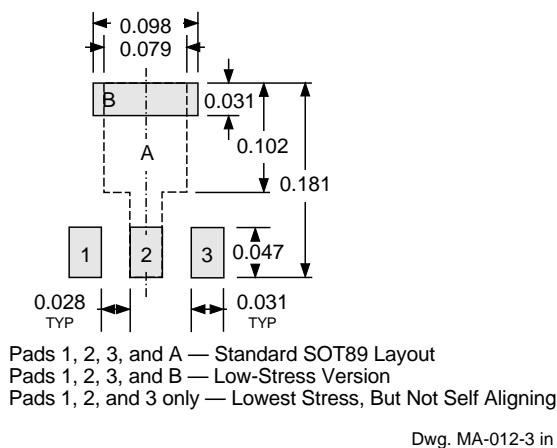
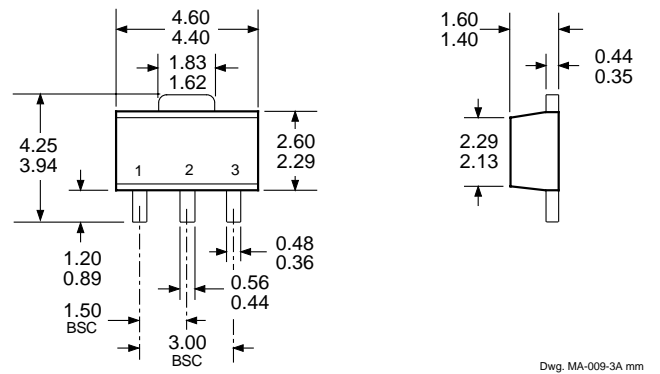

- NOTES: 1. Exact body and lead configuration at vendor's option within limits shown.
2. Supplied in bulk pack (500 pieces per bag) or add "TR" to part number for tape and reel.
3. Only low-temperature ($\leq 240^{\circ}\text{C}$) reflow-soldering techniques are recommended for SOT89 devices.

3161 HALL-EFFECT SWITCH FOR 2-WIRE APPLICATIONS

PACKAGE DESIGNATOR 'UA'

Dimensions in Inches
(controlling dimensions)

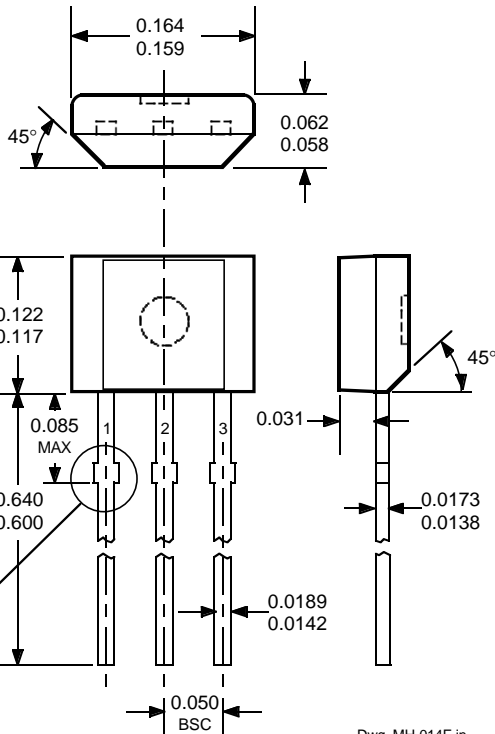

Dimensions in Millimeters
(for reference only)

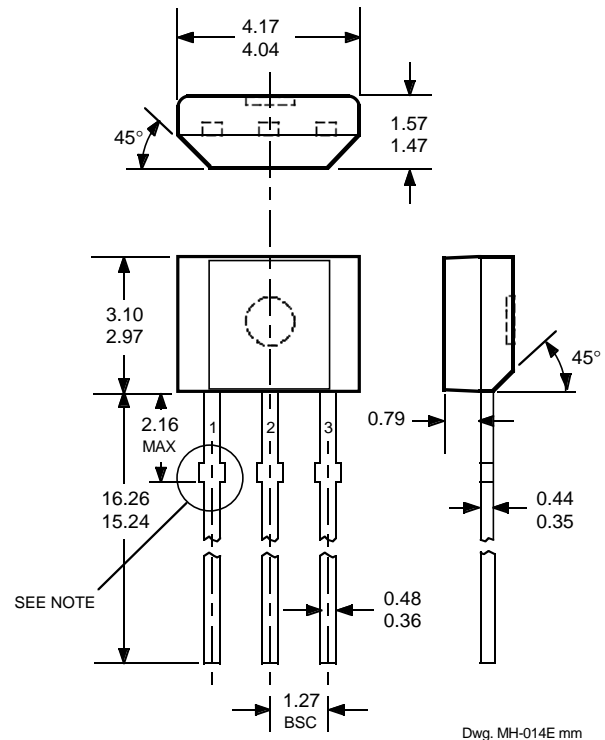

- NOTES:
1. Tolerances on package height and width represent allowable mold offsets. Dimensions given are measured at the widest point (parting line).
 2. Exact body and lead configuration at vendor's option within limits shown.
 3. Height does not include mold gate flash.
 4. Recommended minimum PWB hole diameter to clear transition area is 0.035" (0.89 mm).
 5. Where no tolerance is specified, dimension is nominal.
 6. Supplied in bulk pack (500 pieces per bag).

Radial Lead Form (order A3161EUA-LC)

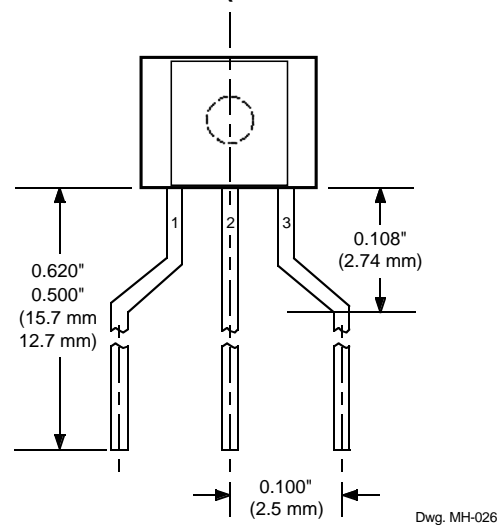

NOTE: Lead-form dimensions are the nominals produced on the forming equipment. No dimensional tolerance is implied or guaranteed for bulk packaging (500 pieces per bag).

3161
HALL-EFFECT SWITCH
FOR 2-WIRE APPLICATIONS

The products described herein are manufactured under one or more of the following U.S. patents: 5,045,920; 5,264,783; 5,442,283; 5,389,889; 5,581,179; 5,517,112; 5,619,137; 5,621,319; 5,650,719; 5,686,894; 5,694,038; 5,729,130; 5,917,320; and other patents pending.

Allegro MicroSystems, Inc. reserves the right to make, from time to time, such departures from the detail specifications as may be required to permit improvements in the performance, reliability, or manufacturability of its products. Before placing an order, the user is cautioned to verify that the information being relied upon is current.

Allegro products are not authorized for use as critical components in life-support appliances, devices, or systems without express written approval.

The information included herein is believed to be accurate and reliable. However, Allegro MicroSystems, Inc. assumes no responsibility for its use; nor for any infringements of patents or other rights of third parties that may result from its use.

3161
HALL-EFFECT SWITCH
FOR 2-WIRE APPLICATIONS

HALL-EFFECT SENSORS

UNIPOLAR HALL-EFFECT DIGITAL SWITCHES						
Partial Part Number	Operate Point (G) Over Oper. Voltage	Release Point (G) & Temp. Range	Hysteresis (G) Range	Oper. Temp.	Packages	Replaces and Comments
A3121x	220 to 500	80 to 410	60 to 150	E, L	LT, UA	3019, 3113, 3119
A3122x	260 to 430	120 to 360	70 to 140	E, L	LT, UA	
A3123x	230 to 470	160 to 330	70 to 140	E, L	LT, UA	
A3141x	30 to 175	10 to 145	20 to 80	E, L	LT, UA	3040, 3140
A3142x	115 to 245	60 to 190	30 to 80	E, L	LT, UA	
A3143x	205 to 355	150 to 300	30 to 80	E, L	LT, UA	
A3144x	35 to 450	25 to 430	>20	E, L	LT, UA	3020, 3120
A3161E	<160 (Typ 130)	>30 (Typ 110)	5 to 80	E	LT, UA	2-wire operation
A3240x	<50 (Typ 35)	>5 (Typ 25)	Typ 10	E, L	LH, LT, UA	chopper stabilized
A3361E	<125	>40	5 to 30	E	LH, LT, UA	2-wire, chopper stabilized, output normally high
A3362E	<125	>40	5 to 30	E	LH, LT, UA	2-wire, chopper stabilized, output normally low

Notes: 1) Typical data is at $T_A = +25^\circ\text{C}$ and nominal operating voltage.

2) "x" = Operating Temperature Range [suffix letter or (prefix)]: S (UGN) = -20°C to $+85^\circ\text{C}$, E = -40°C to $+85^\circ\text{C}$, J = -40°C to $+115^\circ\text{C}$, K (UGS) = -40°C to $+125^\circ\text{C}$, L (UGL) = -40°C to $+150^\circ\text{C}$.