

# *A Practical Guide to 'Free Energy' Devices*

Devices Part 1: Last updated: 29th December 2006

Author: Patrick J. Kelly

## **Introduction**

The purpose of this and the following sections is to provide an introduction to the subject of "Free Energy" or "Zero-Point Energy" (the energy which is seen, even at a temperature of absolute zero). It is by no means exhaustive but is intended to explain clearly and simply, the main sectors of a very large subject. Opinions are expressed on the potential of the various types of equipment and a section on basic electronics construction is included to facilitate the design and construction of control circuits. Internet search engines can locate further information on each person or device mentioned here. I apologise if the presentation seems too elementary, but the intention is to make each description as simple as possible so that everybody can understand it, including people whose native language is not English. If you are not familiar with the basic principles of electronics, then please read the accompanying simple step-by-step electronics tutorial before continuing with this part.

## **Disclaimer**

In case you have skipped the section on basic electronics, let me repeat what was said earlier: These documents are provided for information purposes only. Should you decide to attempt construction of some device based on information presented here and injure yourself or any other person, I am not liable in any way. To clarify this; should you construct something in a heavy box and drop it on your toe, I am not liable for any injury you may sustain (you should learn to be more careful). If you attempt to construct some electronic circuit and burn yourself with the soldering iron, I am not liable. Also, I strongly recommend that unless you are expert in electronics, you do not construct any device using, or producing more than 12 Volts - high voltage circuits are extremely dangerous and should be avoided until you gain experience or can obtain the help and supervision of a person experienced in constructing high voltage circuits.

## **Law of Conservation of Energy**

"Free Energy Devices" or "Zero-Point Energy Devices" are the names applied to systems which produce a higher output power than their input power. There is a strong tendency for people to state that such a system is not possible since it contravenes the Law of Conservation of Energy. It doesn't. If it did, and any such system was shown to work, then the Law would have to be modified to include the newly observed fact. No such change is necessary, it merely depends on your point of view.

For example, consider a crystal set radio receiver:

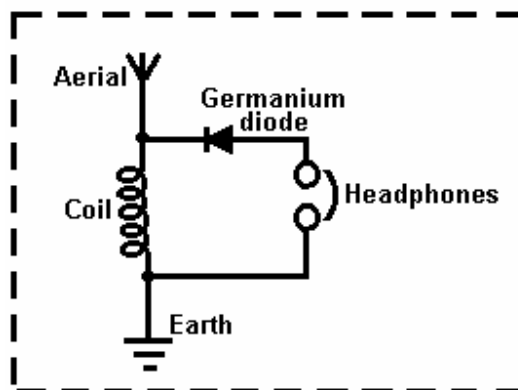

Looking at this in isolation, we appear to have a free-energy system which contradicts the Law of Conservation of Energy. It doesn't, of course but if you do not view the whole picture, you see a device which has only passive components and yet which (when the coil is of the correct size) causes the headphones to generate vibrations which reproduce recognisable speech and music. This looks like Energy Out with no Energy In.

The whole picture is:

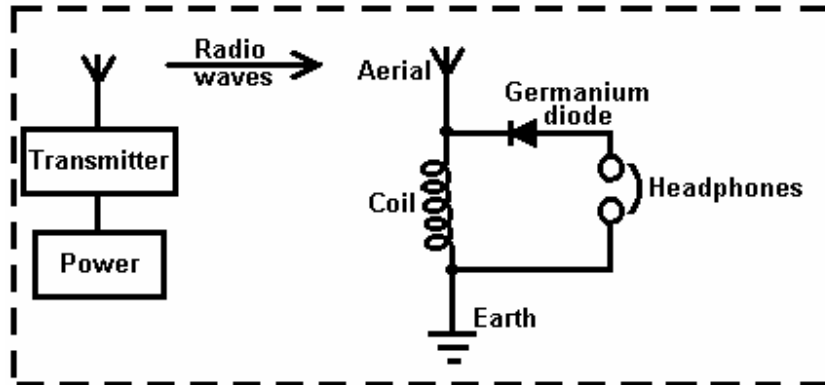

Where the power is supplied to a nearby transmitter which generates radio waves which in turn, induce a small voltage in the aerial of the crystal set, which in turn, powers the headphones. The power in the headphones is far, far less than the power taken to drive the transmitter. There is most definitely, no conflict with the Law of Conservation of Energy. However, there is a quantity called the “Coefficient Of Performance” or “COP” for short. This is defined as the amount of power coming out of a system, divided by the amount of power that **the operator** has to put into that system to make it work. In the example above, while the **efficiency** of the crystal set radio is well below 100%, the COP is greater than 1. This is because the owner of the crystal radio set does not have to supply any power at all to make it work, and yet it outputs power in the form of sound. As the input power needed to make it work is zero, and the COP value is calculated by dividing the output power by this zero input power, the COP is actually infinity. **Efficiency** and **COP** are two different things. Efficiency will never exceed 100% and almost never gets anywhere near 100% due to the losses of any practical system.

As another example, consider a solar panel:

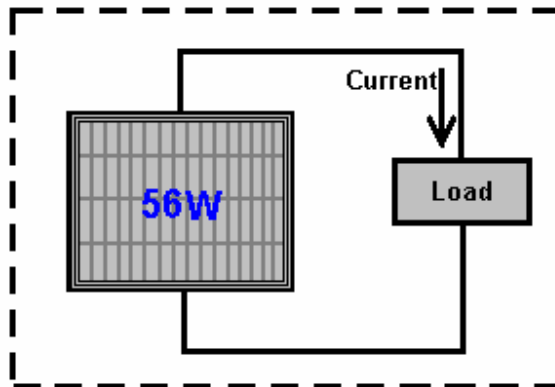

Again, viewed in isolation, this looks like (and actually **is**) a Free Energy device if it is set up out of doors in daylight, as current is supplied to the load (radio, battery, fan, pump, or whatever) without the user providing any input power. Again, Power Out with no Power In. Try it in darkness and you find a different result because the whole picture is:

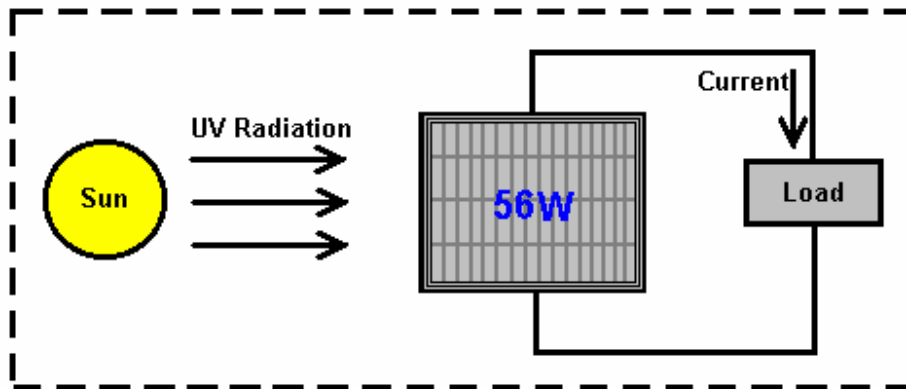

The energy which powers the solar panel comes from the sun.. Only some 17% of the energy reaching the solar panel is converted to electrical current. This is most definitely not a contravention of the Law of Conservation of Energy. This needs to be explained in greater detail. The Law of Conservation of Energy applies to closed systems, and only to closed systems. If there is energy coming in from the environment, then the Law of Conservation of Energy just does not apply.

People sometimes speak of “over-unity” when talking about the efficiency of a system. From the point of efficiency, there is no such thing as “over-unity” as there are always some losses in all practical systems. However, it is perfectly possible to have a system which has a greater power output than the power input which we have to put into it to make it work. Take the solar panel mentioned above. It has a terribly low efficiency of about 17%, **but**, we don’t have to supply it with any power to make it work. Consequently, it’s Coefficient Of Performance (“COP”) is it’s output power (say, 50 watts) divided by the input power needed to make it work (zero watts) which is infinity. So, our humble, well-known solar panel has terrible efficiency of 17% but at the same time it has an infinite COP.

It is now generally accepted that “Dark Matter” and “Dark Energy” form more than 80% of our universe. There is nothing sinister about the adjective “Dark” as in this context, it merely means that we cannot see it. There are many useful things which we utilise, which we can’t see, for example, radio waves, magnetism, gravity, x-rays, etc. etc.

The fact of the matter is, that we are sitting in a vast field of energy which we can’t see. This is the equivalent of the situation for the crystal set shown above, except that the energy field we are in is very, very much more powerful than the radio waves from a radio transmitter. The problem is, how to tap the energy which is freely available all around us.

Some people think that we will never be able to access this energy. Not very long ago, it was widely believed that nobody could ride a bicycle faster than 15 miles per hour because the wind pressure on the face of the rider would suffocate him. Today, many people cycle much faster than this without suffocating - why? - because the original negative opinion was wrong.

Not very long ago, it was thought that metal aircraft would never be able to fly because metal is so much heavier than air. Today, aircraft weighing hundreds of tons fly on a daily basis. Why? - because the original negative opinion was not correct.

It is probably worth while, at this point, to explain the basics of Zero-Point Energy. The experts in Quantum Mechanics refer to how the universe operates as “Quantum Foam”. Every cubic centimetre of “empty” space is seething with energy, so much in fact, that if it were converted using Einstein’s famous equation  $E = mc^2$  (that is Energy = Mass x a Constant), then it would produce as much matter as can be seen by the most powerful telescope. There is actually nothing “empty” about space. So why can’t we see anything there? Well, you can’t actually see energy. All right then, why can’t you measure the energy there? Well, two reasons actually, firstly, we have never managed to design an instrument which can measure this energy, and secondly, the energy is changing direction incredibly rapidly, billions and billions and billions of times each second.

There is so much energy there, that particles of matter just pop into existence and then pop back out again. Half of these particles have a positive charge and half of them have a negative charge, and as they are evenly spread out in three-dimensional space, the overall average voltage is zero. So, if the voltage is zero, what use is that as a source of energy? The answer to that is “none” if you leave it in its natural state. However, it is possible to change the random nature of this energy and convert it into a source of unlimited, everlasting power which can be used for all of the things we use mains electricity for today - powering motors, lights, heaters, fans, pumps, ... you name it, the power is there for the taking.

So, how do you alter the natural state of the energy in our environment? Actually, quite easily. All that is needed is a positive charge and a negative charge, reasonably near each other. A battery will do the trick, as will a generator, as will an aerial and earth, as will an electrostatic device like a Wimshurst machine. When you generate a **Plus** and a **Minus**, the quantum foam is affected. Now, instead of entirely random plus and minus charged particles appearing everywhere, the **Plus** which you created gets surrounded by a sphere of minus charge particles popping into existence all around it. Also, the **Minus** which you created, gets surrounded by a spherical-shaped cloud of plus-charge particles popping into existence all around it. The technical term for this situation is “**broken symmetry**” which is just a fancy way of saying that the charge distribution of the quantum foam is no longer evenly distributed or “symmetrical”. In passing, the fancy technical name for your **Plus** and **Minus**, is a “**dipole**” which is just a techno-babble way of saying “two poles: a plus and a minus” - isn't jargon wonderful?

So, just to get it straight in your mind, when you make a battery, the chemical action inside the battery creates a Plus terminal and a Minus terminal. That actually distorts the universe around your battery, and causes vast streams of electromagnetic energy to radiate out in every direction from each pole of the battery. Why doesn't the battery run down? Because the energy is flowing from the environment and not from the battery. If you were taught basic physics or electrical theory, you will probably have been told that the battery used to power any circuit, supplies a stream of electrons which flows around the circuit. Sorry Chief - it just ain't like that at all. What really happens is that the battery forms a “dipole” which nudges the local environment into an unbalanced state which pours out energy in every direction, and some of that energy from the environment flows around the circuit attached to the battery. The energy does **not** come from the battery.

Well then, why does the battery wear out, if no energy is being drawn from it to power the circuit? Ah, that is the really silly thing that we do. We create a closed-loop circuit (because that's what we have always done) where the current flows around the circuit, reaches the other battery terminal and immediately destroys the battery's “dipole”. Everything stops dead in its tracks. The environment becomes symmetrical again, the massive amount of readily available free-energy just disappears and you are back to where you started from. **But**, do not despair, our trusty battery immediately creates the Plus and Minus terminals again and the process starts all over again. This happens so rapidly that we don't see the breaks in the operation of the circuit and it is the continual recreation of the dipole which causes the battery to run down and lose its power. Let me say it again, the battery does **not** supply the current that powers the circuit, it never has and it never will - the current flows into the circuit from the surrounding environment.

What we really need, is a method of pulling off the power flowing in from the environment, without continually destroying the dipole which pushes the environment into supplying the power. That is the tricky bit, but it has been done. If you can do that, then you tap into an unlimited stream of inexhaustible energy, with no need to provide any input energy to keep the flow of energy going. In passing, if you want to check out the details of all of this, Lee and Yang were awarded the Nobel Prize for Physics in 1957 for this theory which was proved by experiment in that same year. This set of documents includes circuits and devices which manage to tap this energy successfully.

Today, many people have managed to tap this energy but no commercial device is readily available. The reason for this is human rather than technical. Some 3,000 Americans have produced devices or ideas for devices but none have reached commercial production due to opposition from influential people who do not want such devices freely available. One technique is to classify a device as “essential to US National Security”. If that is done, then the developer is prevented from speaking to anyone about the device, even if he has a patent. He cannot produce or sell the device even though he invented it. Consequently, you will find many patents for

perfectly workable devices if you were to put in the time and effort to locate them. This series of documents is intended to present a digest of some of the device types which may be worth investigating. To summarise:

**1. Energy can be captured directly via an aerial system or similar device**

Thomas Henry Moray, Nikola Tesla, Frank Prentice, Hermann Plauston, Roy Meyers

**2. Energy can be captured via a strong and very brief magnetic pulse**

Ed Gray snr., Alfred Hubbard, Robert Adams/Tim Harwood, John Bedini, Bob Teal, etc.

**3. Energy can be returned to a battery power source by its own load**

Tesla 4-battery system, Bedini 3-battery system, Bedini 1-battery system

**4. Energy can be taken from “permanent” magnets**

Howard Johnson, Nelson Camus, John Bedini, Hans Coler, Floyd Sweet, Tom Bearden

**5. If hydrogen can be efficiently split, then energy is available when it is recombined**

Stanley Meyer, Henry Puharich, Paulo Mateiro, Charles Garrett, Archie Blue

**6. There are several other systems which are not likely to produce practical devices**

Homopolar, Tesla Coils, Lutec, Mini-Romag (JLN), cold fusion

In more detail:

**1. Energy can be captured directly via an aerial system or similar device**

These systems demonstrate that an energy field exists and that it can be tapped directly if the physical arrangement is correctly set. Conjurers being so adept, it is possible that these devices are fraudulent, but the weight of supporting evidence is so great that I personally, am inclined to accept the accounts as stated. While this body of information is notionally split into different sections, the nature of free-energy is such that devices which appear on the surface to be quite different from each other, are eventually seen to be very close in operation since most of them are tapping the same vast energy field, although they appear to do it in different ways.



**Thomas Henry Moray** In this field, Thomas Henry Moray is outstanding. By 1936 he had developed a piece of apparatus which was capable of putting out high power with no human-generated input power at all. The equipment is said to have contained a germanium diode which he built himself in the days before solid-state devices became readily available. The equipment was examined and tested many times. On dozens of occasions, he demonstrated the equipment driving a bank of twenty 150W bulbs, plus a 600W heater, plus a 575W iron (a total of 4.175 kW). The power picked up by this device needed only small diameter wires and had characteristics different from conventional electricity. One demonstration which was repeated many times, was to show that the output power circuit could be broken and a sheet of ordinary glass placed between the severed ends of the wire, without disrupting the supply. This type of power is called “Cold electricity” because thin wires carrying major power loads, do not overheat. This form of energy is said to flow through vacuum polarisation waves which surround the wires and, unlike conventional electricity, it does not use electrons for transmission and that is why it can continue through a sheet of glass which would stop conventional electricity dead in its tracks.

On one occasion, Moray took his equipment away from all urban areas to a place chosen at random by a critic. He then set up the equipment and demonstrated the power output, well away from any man-generated electrical induction. He disconnected the aerial and showed that the power output stopped immediately. He connected the aerial again to generate the output as before. He then disconnected the earth connection which stopped the output again. When the earth wire was connected again, the output power returned. He found that the power output level fell somewhat at night.

He developed various versions of the device, the latest of which did not need the aerial or earth connections, weighed 50 pounds and had an output of 50 kilowatts. This device was tested in both an aeroplane and a submarine, thus showing the device to be fully self-contained and portable. It was also tested in locations which were fully shielded from electromagnetic radiation.

Moray was shot and wounded in an assassination attempt in his laboratory. This caused him to change the glass in his car to bullet-proof glass. He was threatened many times. His demonstration equipment was smashed with a hammer. When threats were made against his family, he stopped rebuilding his equipment and appeared to have turned his attentions to other things, producing a device for 'therapeutic' medical treatment.

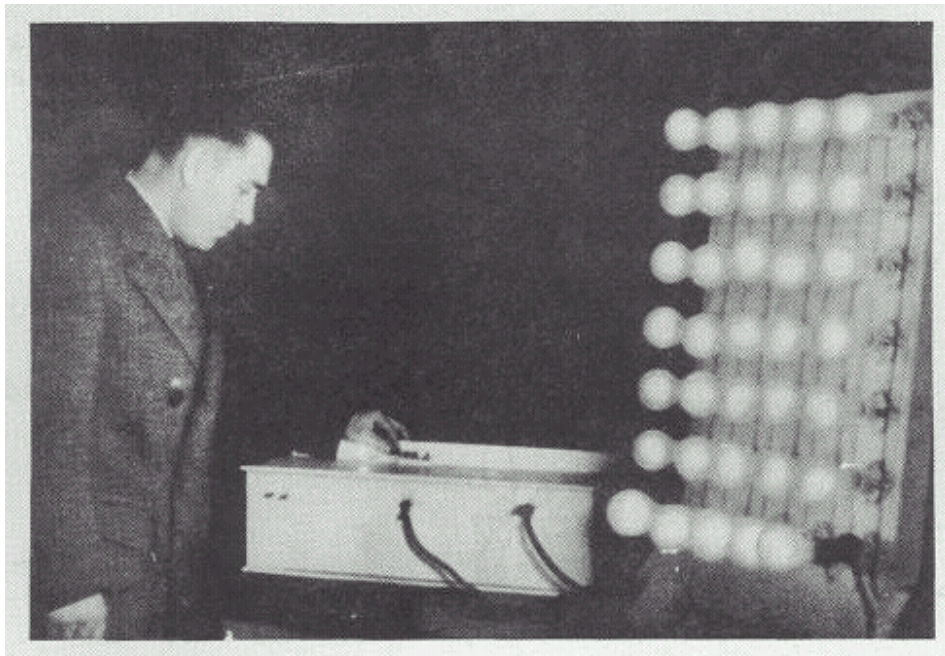

In his book "The Energy Machine of T. Henry Moray", Moray B. King provides more information on this system. He states that Moray was refused a patent on the grounds that the examiner couldn't see how the device could output so much power when the valve cathodes were not heated. Moray was granted US Patent 2,460,707 on 1st February 1949 for an Electrotherapeutic Apparatus, in which he included the specification for the three valves used in his power device, apparently because he wanted them to be covered by a patent. As far as can be seen, the valve shown here is an oscillator tube. Moray claimed that this tube had the very high capacitance of 1 Farad when running at its resonant frequency. Moray liked to use powdered quartz as a dielectric in the capacitors which he made, and he had a habit of mixing in radium salts and uranium ores with the quartz. These materials may well be important in producing ionisation in these tubes and that ionisation may well be important in tapping the energy field.

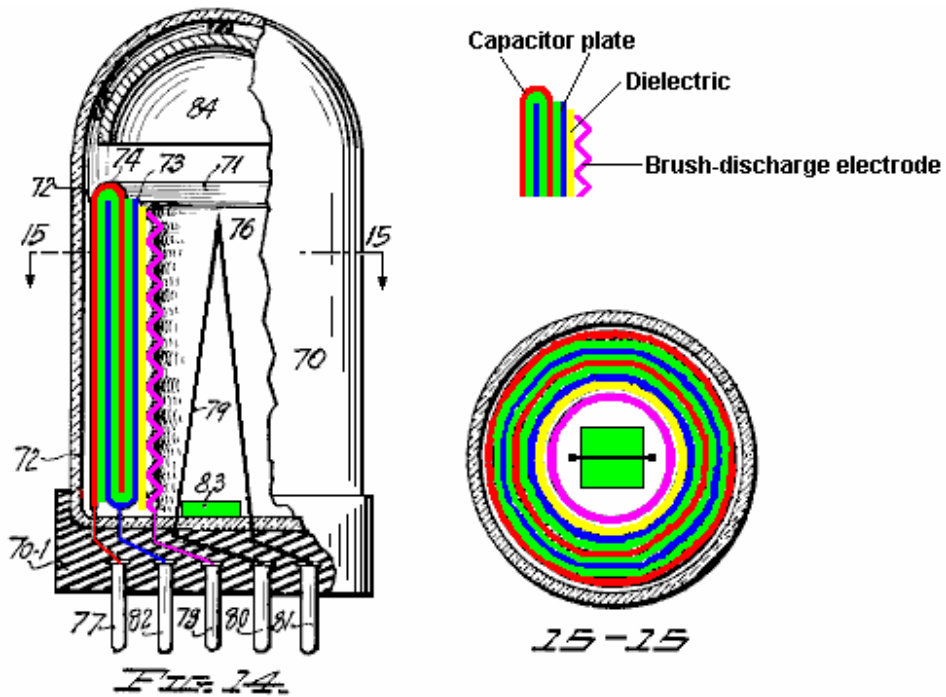

The tube shown above has a six-layer capacitor formed from two U-shaped metal rings with the space between them filled with a dielectric material. The plates are shown in red and blue, while the dielectric is shown in green. Inside the capacitor, there is a separate ring of dielectric material (possibly made from a different material) and an inside ring of corrugated metal to form an ion brush-discharge electrode. The capacitor and electrode connections are taken to pins in the base of the tube. Quartz is suggested for the material of the outer covering of the tube and the wire element numbered **79** in the diagram is said to be a heating element intended to be powered by a low-voltage current source. However, as Moray had an earlier patent application refused on the grounds that there was no heating element in his tubes, it is distinctly possible that the heating element shown here is spurious, and drawn solely to avoid rejection by the examiners. In his patent, Moray refers to the capacitor in this tube as a "sparking" capacitor, so he may have been driving it with excessively high voltages which caused repeated breakdown of the capacitor material. If this is so, then there appears to be a considerable degree of similarity between his tube and that used by Edwin Gray snr. which is described later in this document.

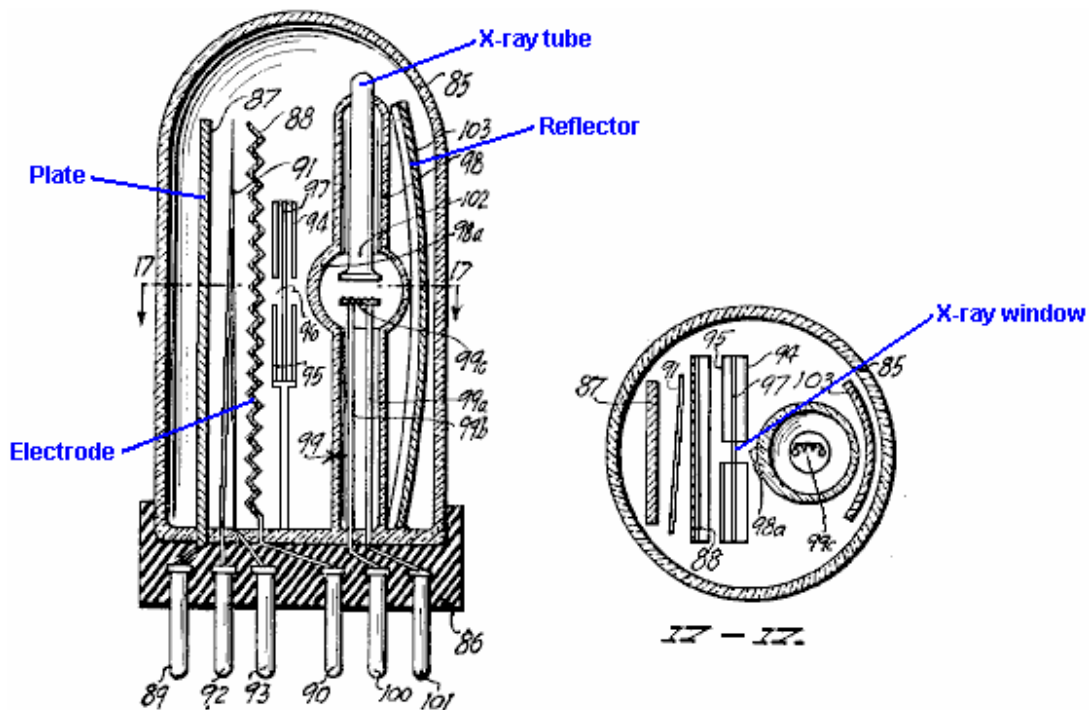

FIG. 16.

The tube of Fig.16 above, uses a different technique where an X-ray tube is used to bombard a corrugated electrode through a screen containing an X-ray window. It is thought that a brief burst of X-rays was used to trigger very short, sharp bursts of ions between the anode and cathode of the tube and these pick up extra energy with every burst.

An alternative version of this tube is shown in Fig.18 below. here the construction is rather similar but instead of an X-ray window, a lens and reflector are used to cause the ionisation of the switching channel between the anode and cathode. In both tubes, the corrugated electrode supports a corona build-up just prior to the short X-ray switching pulse, and it is thought that the ions contribute to the intensity of the resulting pulses which emerge from the tube. Very short uni-directional pulses are capable of causing conditions under which additional energy can be picked up. From where does this extra energy come? In 1873, James Clerk Maxwell published his "treatise on Electricity and Magnetism" and in it he pointed out that the vacuum contains a considerable amount of energy (Vol. 2, p. 472 and 473). John Archibald Wheeler of Princeton University, a leading physicist who worked on the US atomic bomb project, has calculated the flux density of the vacuum. This energy field is referred to as "Universal Energy", "Gravity Field Energy" or "Zero Point Energy".

The existence of this energy field is now widely accepted by mainstream science and it is borne out by the situation found at quantum levels. It is generally thought that this energy is chaotic in form and for useful energy to be drawn from it, it needs to be restructured into a coherent form. It appears that uni-directional electromagnetic pulses of one millisecond or less, can be used to cause the necessary restructuring as they generate an outward coherent wave of radiant energy, from which energy can be extracted for use in most electrical devices, if a suitable receptor system is used.

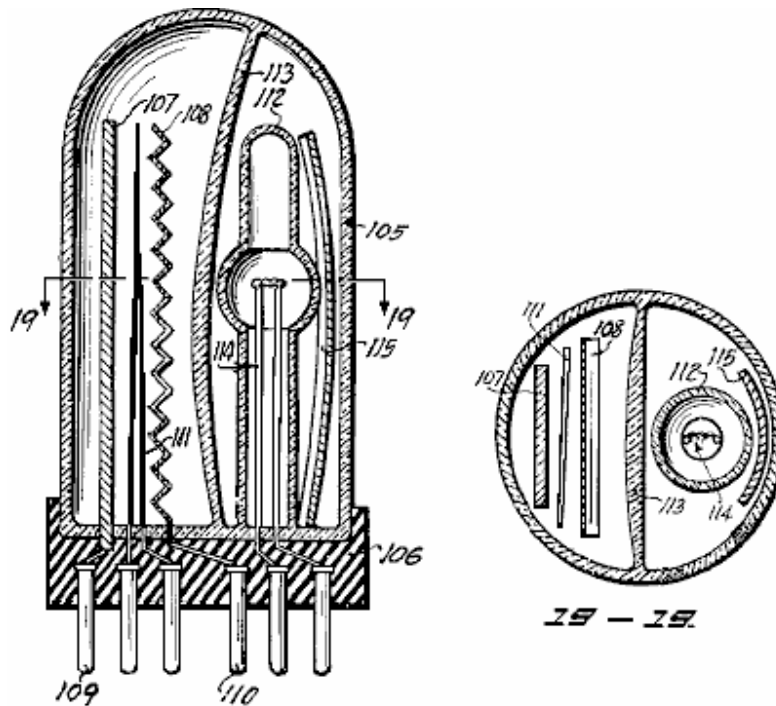
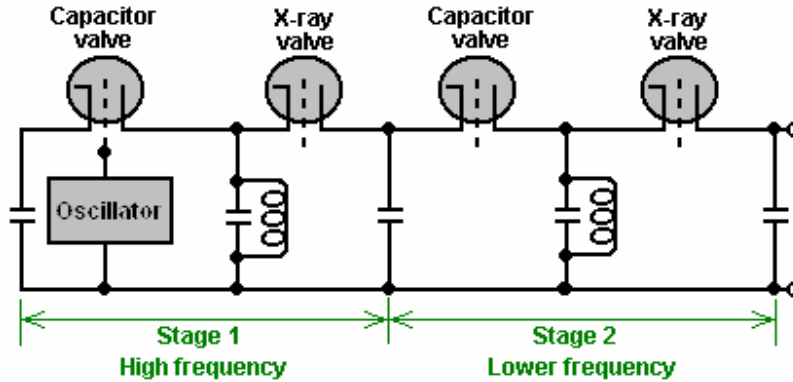

FIG. 28.

Moray King suggests that the circuit used by Thomas Moray was as follows:



There can be little doubt that Thomas Henry Moray built several versions of his apparatus, each of which produced output power well in excess of any input power needed. It seems highly likely that most of them used no input power whatsoever, and if there were any others, they will have been powered by a tiny fraction of the output power. If mild radioactive material was used as described, then the output power could in no way be attributed to that source alone, since the output power was thousands of times greater than any power available from the radioactive materials.

It is perhaps time to explain a little more about voltage, power and current. We have been raised with the notion that it is necessary to “burn” a fuel to get power, that batteries “run down” when used and that you have to keep turning the shaft of an electrical generator to be able to draw current from it. These things are not actually true. The relatively recent field of Quantum Mechanics shows that if a charge, such as an electron has, is positioned in what is supposed to be “empty” space, it is not alone. The “empty” space is actually seething with energy, to the extent that “virtual” particles are popping into existence for a fraction of a second and then disappearing again. They are called “virtual” because they exist for such a short time.

Because of the negative charge of the electron, the particles appearing and disappearing around it will all be positive in charge. The electron has “polarised” the space around itself because it has a charge. The instant that a positive “virtual” particle appears, there are two charges near each other - minus on the electron and plus on the particle. When you have two opposite charges near each other, they form a “dipole”. Dipoles form a gateway through which energy from the environment flows continuously. An instant later, the particle disappears, but its place is immediately taken by another virtual particle. The result is a continuous stream of energy flowing through the dipole.

Batteries with their positive and negative terminals are electrical dipoles as are generators when the input shaft is spun. Permanent magnets with their North and South poles are magnetic dipoles. Both of these have continuous streams of energy flowing through them. So, why then do batteries run down and lose their charge? The reason is that we power circuits using a closed loop. The energy flowing out of one terminal flows into the opposite terminal and instantly destroys the dipole. A new dipole has to be created every split second if the circuit is to deliver power, and it is that self-destructive method of use which causes the battery to discharge or which needs the generator shaft to be rotated continuously.

If a different operating technique is used, where the dipole is not continuously destroyed, then devices which can provide a continuous stream of energy drawn from our natural environment can be constructed. This is not magic, just the next step in conventional science and engineering. Thomas Henry Moray managed it, initially with an aerial and earth like a crystal set to provide the dipole, his device was able to draw many kilowatts of power from the environment. No fuel was needed, the energy is already there surrounding us all, all of the time. The aim of these documents is to make you aware of some of these devices and to help you understand how they operate.

**Nikola Tesla:** Nikola Tesla produced a similar device which is probably worth mentioning here. It was patented on Mat 21st 1901 as an “Apparatus for the Utilisation of Radiant Energy”, US Patent number 685,957.



The device appears simple but Tesla states that the capacitor needs to be “of considerable electrostatic capacity” and he recommends using the best quality mica to construct it as described in his 1897 patent 577,671.

The circuit is powered via an insulated, shiny metal plate. The insulation could be spray-on plastic. The larger the plate, the greater the energy pick-up. The higher the plate is elevated, the greater the pick-up.

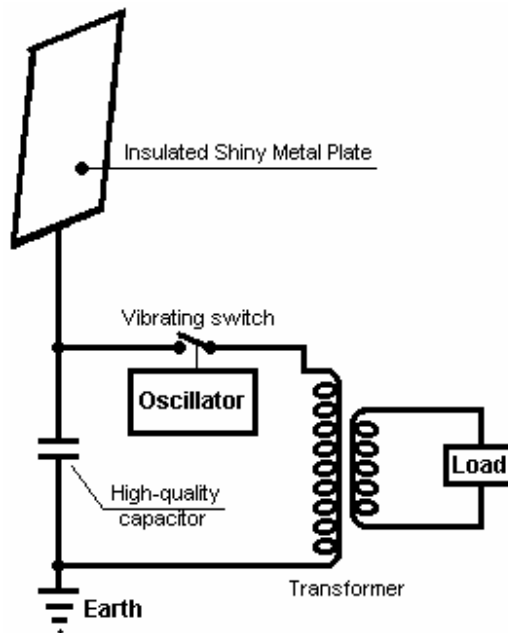

**Tesla's Radiant Energy Device**

Like Moray's system, Tesla's system picks up energy day and night. The capacitor gets charged up and a vibrating switch repeatedly discharges the capacitor into the transformer. The transformer output is then used to power the load.

It seems probable that this device operates primarily from static electricity, which some people believe is a manifestation of the zero-point energy field. It is possible that Moray's equipment also operated by tapping static electricity but this is probably less likely. Tesla's equipment might well operate when fed by a motor-driven Wimshurst machine instead of a large aerial plate. Details of home-built Wimshurst equipment are available in the book 'Homemade Lightning' by R.A. Ford, ISBN 0-07-021528-6.

Tesla also designed a device for picking up energy from the air. As far as I am aware, it was never patented and I have never seen a specification of its output. Perhaps it was one of Tesla's failures but personally, I doubt that. It might make a very interesting experiment so see what level of output can be achieved using it. The construction is shown here:

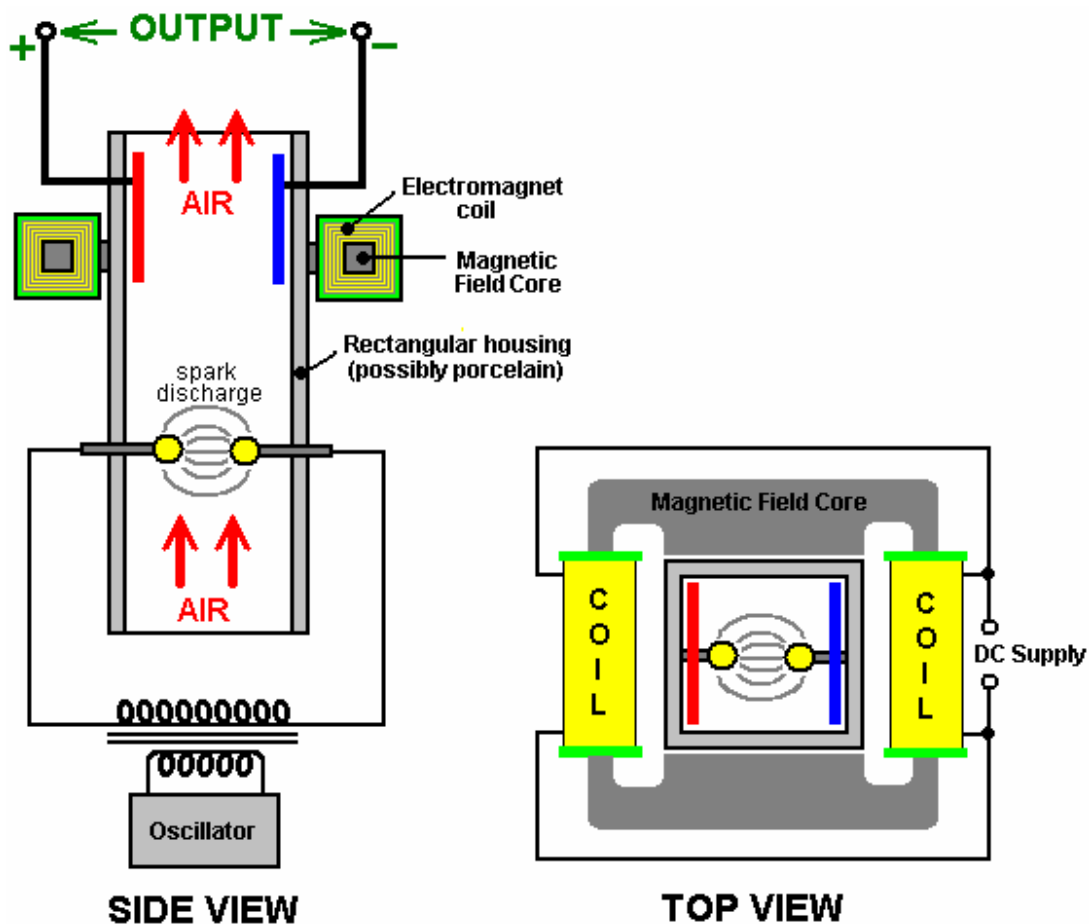

It is essentially, a rectangular cylinder which contains two spherical electrodes like a Wimshurst machine. The cylinder is positioned vertically, so that when the electrodes are powered up with high voltage to create spark discharges, the air inside the cylinder is heated which causes it to rise up the cylinder. The heated air is ionised, so a magnetic field generated by a surrounding electromagnet, causes the charged ions to move to opposite sides of the cylinder. Electrode plates positioned inside the cylinder, provide an electrical path for the excess positive and negative charges to flow together through the load - lighting, heating or motor circuits typically.

On the surface, this system would appear to be less than 100% efficient, in that the amount of power applied to the device to make it operate should be less than the amount of power drawn from it to drive useful loads. I am not sure that this is necessarily so. Firstly, the air already contains charged ions before this device starts to generate more. These naturally occurring ions gain in number when a thunderstorm is likely, even to the extent of giving many people a headache by their presence. These naturally occurring ions will be picked up by this device and without any input power needed to create them, they are capable of providing output power.

Also, the whole earth is immersed in the zero-point energy field. This is seething energy at the quantum level whose effects can be seen even at 'absolute zero'. This field is made of small random effects which makes it hard to obtain useful energy directly from it. The field needs to be structured before energy can be drawn from it. One way to do this is to align the field with an event which causes coherent waves of energy to radiate outwards as a 'radiant energy' wave - something like the ripples caused on the surface of a pond of still water when a large stone is dropped vertically into the water. The ripple 'waves' move outwards from the 'event' until they reach the bank of the pond. If there was a generator attached to a float in the pond, it would be possible to pick up some energy from the ripples. The same can be done with 'radiant energy' waves if you can create them and know how to pick up energy from them.

Radiant energy waves can be formed by very short sharp uni-directional electrical pulses. Pulses less than one hundredth of a second are suitable for this. One way of creating pulses of that type is using a spark gap. In Tesla's device shown above, sparks are generated continuously. These sparks will generate radiant energy waves radiating out at right angles to the spark. Without a doubt, the vertical cylinder will have a mass of radiant energy shooting up it when it is being operated. This is in addition to the air ions which are being picked up. The only question is whether or not the electrode plate arrangement shown is capable of picking up any of this excess energy. Considering the metallic pickup device used by Edwin Gray to capture radiant energy as described below, it seems highly likely that some of that additional energy is, in fact, picked up and used to power the loads.

It should be noted that Tesla's device shown above, will generate UV radiation in the same way as any MIG or stick welder does, so care should be exercised to avoid looking at the arc or allowing the UV to shine on your skin, even if the skin is covered by clothing. You can get serious sunburn through thin clothing if it is subjected to strong UV radiation. Also, radio interference is likely to be generated by the arc, so screening should be provided during any tests. **WARNING:** Tesla accidentally discovered that electric spark discharges in air, ignite and burn atmospheric oxygen and nitrogen, producing 12,000,000 volt waves. The oxygen and nitrogen, both below atomic number 19 are thereby transmuted into alpha and beta charges (stripped helium nuclei with +2 charge each, and electrons with -1 charges each) by the powerful radiation produced, having a voltage potential of 12 Mev. This is almost three times the Mev level of gamma radiation emitted by radium, it may well be the reason why Tesla did not publicise the device shown above, and should you decide to experiment with it, please be aware of the potential hazard of this radiation.

A variation on the above device of Tesla's is given in the book "Physical Chemistry" by E. A. Moelwyn-Hughes, Pergamon Press, Oxford 1965, page 224. Rutherford and Geiger determined the fact that radium puts out alpha particles at the rate of 34,000,000,000 per second, each having two units of positive charge at 4.5 million electron-volts. This is a staggering amount of energy which ionises the air inside the housing and produces enough power to be capable of replacing the entire Four Corners power complex indefinitely.

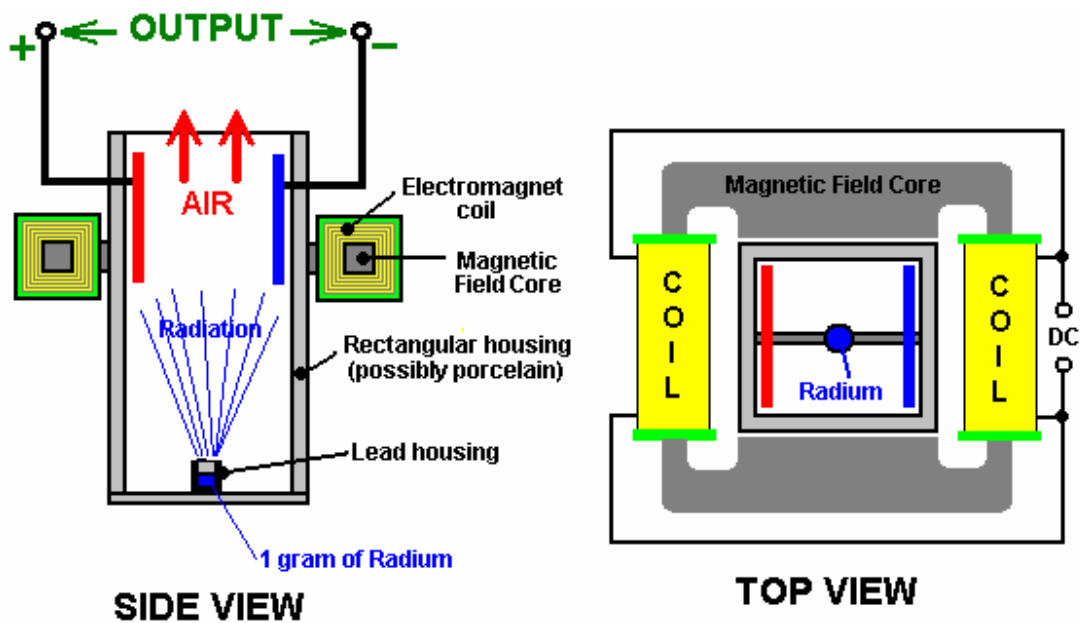

The variation of Tesla's device shown above, supports the lead container with its gram of radium on a strap across the bottom of the housing. The radiation ionises the air and the magnetic field separates the charges and directs them to opposite sides of the housing, to be collected and used via the electrode plates. There does not appear to be any reason why strong permanent magnets should not be used instead of the DC electromagnet shown.

**Frank Prentice.** Electrical Engineer Frank Wyatt Prentice of Pennsylvania, USA invented an 'Electrical Power Accumulator' with an output power six times greater than the input power. He was granted a patent on 18th September 1923 and its re-worded contents are as follows:

My invention relates to improvements in Electrical Power Accumulators, wherein the earth acting as rotor and the surrounding air as a stator, collects the energy thus generated by the earth rotating on its axis, utilises the same for power and other purposes.

In the development of my Wireless Train Control System for railways, covered by my United States Letters Patent Number 843,550, I discovered that, with an antennae consisting of one wire of suitable diameter supported by insulating means three to six inches above the ground and extending one half mile, more or less in length, the said antennae being grounded at one end through a spark gap and energised at the other end by a high frequency generator of 500 Watts input power and having a secondary frequency of 500,000 Hz, would produce in the antenna an oscillatory frequency the same as that of the earth currents and thus electrical power from the surrounding media was accumulated along the length of the transmission antenna and with a closed oscillatory loop antenna 18 feet in length run parallel with the transmission antenna at a distance of approximately 20 feet it was possible to obtain by tuning the loop antennae, sufficient power to light to full power, a series bank of fifty 60 watt carbon lamps.

Lowering or raising the frequency of 500,000 Hz resulted in diminishing the amount of power received on the 18 foot antenna. Similarly, raising the transmission antenna resulted in a proportionate decrease of power picked up on the receiving antenna and at 6 feet above the earth no power at all was obtainable without a change of potential and frequency.

It is the objective of my generic invention to utilise the power generated by the earth as described here, and illustrated in the drawings. The two figures in the drawings illustrate simple and preferred forms of this invention, but I wish it understood that no limitation is necessarily made as to the exact and precise circuits, shapes, positions, and structural details shown here, and that changes, alterations and modifications may be made when desired within the scope of my invention and as specifically pointed out in the claims.

DESCRIPTION OF DRAWINGS:

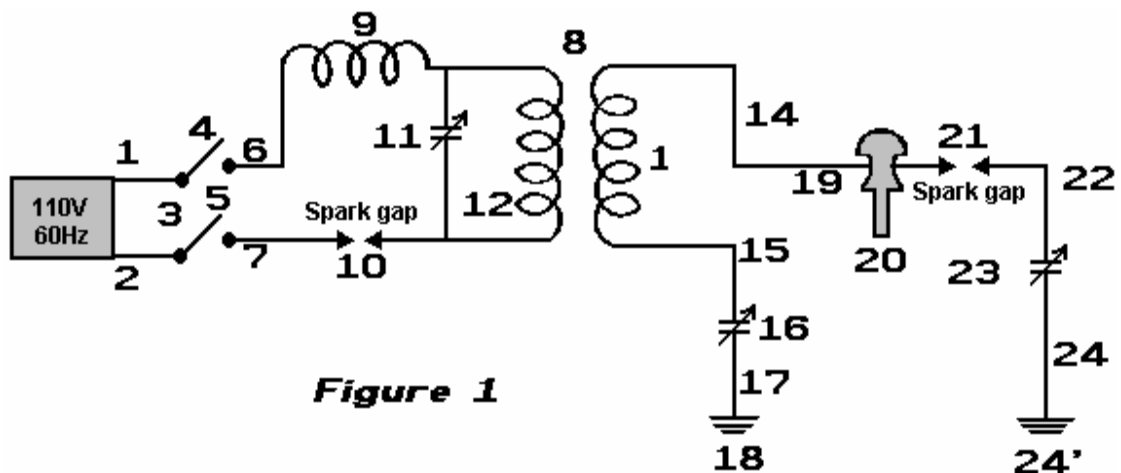
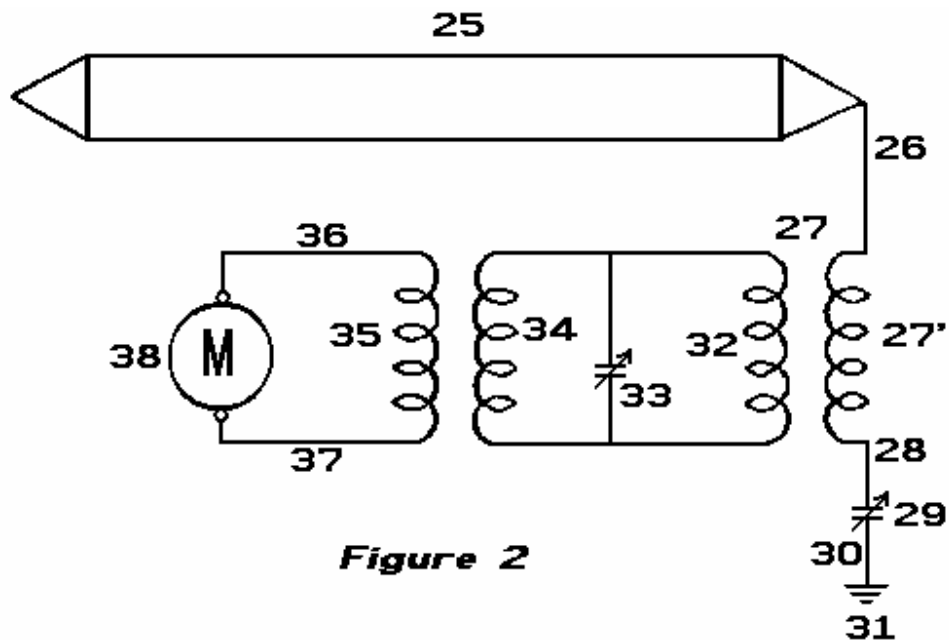

**Figure 1**

In Fig.1:

1 and 2 are alternating current feed wires supplying 110 volts 60 cycles to a high frequency generator. 3 is a switch with poles 4 and 5.

6 and 7 are connections of high frequency transformer 8 for stepping up the frequency to 500 KHz and the voltage to say 100 KV.  
 9 is an inductance coil.  
 10 is a spark gap.  
 11 is a variable capacitor.  
 12 is the primary winding of transformer 8.  
 13 is the secondary winding of transformer 8 which is connected through wire 15 via variable capacitor 16 and wire 17 to ground 18.  
 14 is the wire from the other side of the secondary winding of transformer 8 connecting it to the main transmission antenna 19 which is supported by insulating means 20.  
 21 is spark gap from transmission antenna 19 to ground through wire 22, variable capacitor 23, and wire 24 to ground 24'.  
 Transmission antenna 19 may be of any desired length.



**Figure 2**

In Fig.2:

25 is a closed oscillating loop antenna of any desired length, which for greatest efficiency, is run parallel with transmission antenna 19 of Fig.1.  
 26 is the connecting lead between the antenna and step-down transformer 27 of which 27' is the secondary.  
 28 is the lead connecting the secondary winding 27' to ground 31 via variable capacitor 29 and lead 30.  
 32 is the primary winding of transformer 27.  
 33 is a variable capacitor.  
 34 and 35 are frequency transformer windings, supplying current through leads 36 and 37 to motor 38, or any other power devices.

**OPERATION OF THE INVENTION:**

Close switch **3** to connect feed wires **1** and **2** to transformer leads **6** and **7**.

Adjust spark-gap **10** and variable capacitor **11** so that a frequency of 500 KHz and 100 KV is delivered from secondary leads **14** and **15** of step-up transformer **8** of **Fig.1**.

Next adjust spark-gap **21** of transmission antenna **14** so that all nodes and peaks are eliminated in the transmission of the 100 KV and 500 KHz frequency along antenna **14**.

The surges which occur, pass over gap **21** through lead **22** to variable capacitor **23** and then on to ground **24'** via lead **24**.

The high frequency current of 500 KHz returns through the ground, to ground connection **18**, up lead **17** to the variable capacitor **16** and via lead **15** to the secondary winding **13** of transformer **8** of **Fig.1**.

The alternating current produced by the 100 KV 500 KHz supply is the same frequency as the earth generated currents, and being in tune with them it picks up additional power from them.

Being the same frequency as the output from transformer **8** along wires **14**, this produces a reservoir of high frequency current which can be drawn upon by a tuned circuit of the same 500 KHz frequency, as shown in **Fig.2**.

Antenna **25** is tuned to receive a frequency of 500 KHz which produces a current that passes to lead **26** through winding **27'** of transformer **27**, through wire **28**, variable capacitor **29** and wire **30** to ground connection **31**.

The high frequency currents of 500 KHz pass through to winding **32** and by variable capacitor **33** and windings **34** and **35** of the frequency transformer **27** are stepped down to a voltage and frequency suitable to operate motor **38** via leads **36** and **37**. This makes available a current supply for any purpose whatsoever, such as the operation of aeroplanes, cars, railway trains, industrial plants, lighting, heating etc.

The return of current through the earth from transmission antenna **14** is preferable to a metallic return as a higher percentage of accumulation of earth currents is noticeable on receiving antennae of **Fig.2** than from a metallic return, caused by the capacitance of the grounded circuit. I also prefer under certain conditions to use a single antenna receiving wire in place of the closed loop shown in **Fig.2**.

Under certain operation requirements I have found it expedient to have the transmission antenna elevated and carried on poles many feet above the earth and in that case a different voltage and frequency were found to be necessary to accumulate earth currents along the transmission antenna **14**.

**Hermann Plauston.** Hermann Plauston was granted US Patent 1,540,998 in June 1925. The patent is similar in style to Tesla's pick-up system and it illustrates the principle with a system which is very much like Paul Baumann's "Testatica" device described later on. The patent is very detailed with 37 drawings showing different arrangements, and it forms part of this information set. In fact, the patent reads more like a tutorial rather than a patent. A system of this type should most definitely be taken seriously: Hermann considers one of his systems with an output of 100 kilowatts as being a "small" system. He illustrates several different methods of energy capture and several methods of increasing the effectiveness of the captured energy. While an installation to capture a continuous supply of 100+ kilowatts is unrealistic for an individual, there is the distinct possibility of making a scaled-down version which is capable of providing serious levels of free power. Reading his patent through carefully is definitely to be recommended.

Herman starts by illustrating how working electricity can be taken from a Wimshurst machine. The Wimshurst output voltage is very high and the current capacity is very low. Hermann adjusts this by feeding the output into a step-down transformer which lowers the output voltage to a convenient level and raises the available current in proportion to the reduction in voltage. The apparatus which he illustrates is shown here:

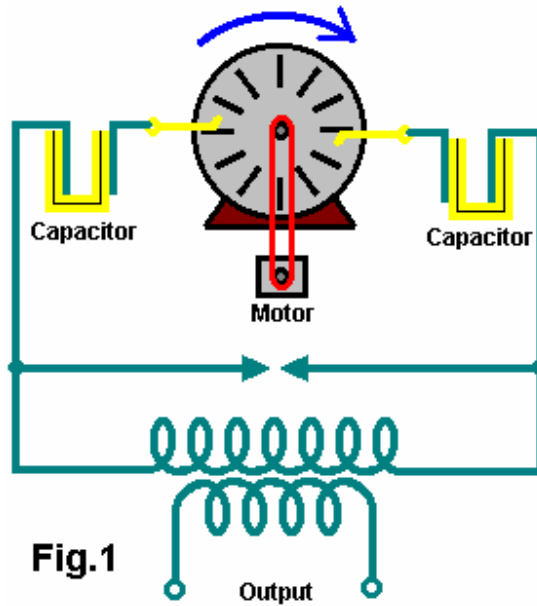

His patent says: "By suitably selecting the ratio between the number of turns in the primary and secondary windings, with regard to a correct application of the coefficients of resonance (capacitance, inductance and resistance) the high voltage of the primary circuit may be suitably converted into a low voltage high current output.

When the oscillatory discharges in the primary circuit become weaker or cease entirely, the capacitors are charged again by the static electricity until the accumulated charge again breaks down across the spark gap. All this is repeated as long as electricity is produced by the static machine through the application of mechanical energy to it.

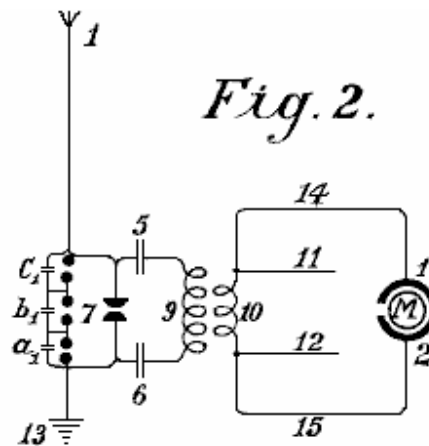

An elementary form of the invention is shown in **Fig.2** in which two spark gaps in parallel are used, one of which may be termed the working gap **7** while the second serves as a safety device for excess voltage and consists of a larger number of spark gaps than the working section, the gaps being arranged in series and which are bridged by very small capacitors  $a_1$ ,  $b_1$ ,  $c_1$ , which allow uniform sparking in the safety section.

**A** is the aerial antenna for collecting charges of atmospheric electricity, **13** is the earth connection of the second part of the spark gap, **5** and **6** are capacitors and **9** is the primary coil winding. When the positive atmospheric electricity seeks to combine with the negative earth charge via aerial **A**, this is prevented by the air gap between the spark gaps. The resistance of spark gap **7** is lower than that of the safety spark gap set of three spark gaps connected in series a which consequently has three times greater air resistance.

Therefore, so long as the resistance of spark gap 7 is not overloaded, discharges take place only through it. However, if the voltage is increased by any influence to such a level that it might be dangerous for charging the capacitors 5 and 6, or for the coil insulation of windings 9 and 10, the safety spark gap set will, if correctly set, discharge the voltage directly to earth without endangering the machine. Without this second spark gap arrangement, it is impossible to collect and render available large quantities of electrical energy.”

In addition to the use of spark gaps in parallel, a second measure of security is also necessary for taking the current from this circuit. This is the introduction of protective electromagnets or choking coils in the aerial circuit as shown by S in Fig.3. A single electromagnet having a core of the thinnest possible separate laminations is connected with the aerial. In the case of high voltages in the aerial network or at places where there are frequent thunderstorms, several such magnets may be connected in series.

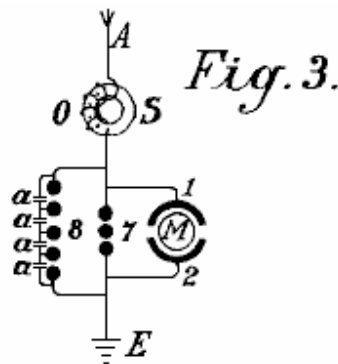

In the case of large units, several such magnets can be employed in parallel or in series parallel. The windings of these electromagnets may be simply connected in series with the aerials. In this case, the winding preferably consists of several thin parallel wires, which together, make up the necessary cross-sectional area of wire. The winding may be made of primary and secondary windings in the form of a transformer. The primary winding will then be connected in series with the aerial network, and the secondary winding more or less short-circuited through a regulating resistor or an induction coil. In the latter case it is possible to regulate, to a certain extent, the effect of the choking coils.

The patent continues by showing many ways to increase the power of the aerial system and many ways of applying the output to practical electrical devices and it forms part of this set of documents.

**Roy Meyers.** Roy Meyers was granted UK Patent 1913,01098 in January 1914. The patent, which is included in this set of documents, shows an extremely simple device which produces an electrical output without any form of visible input whatsoever. This intriguing device was discovered in a very simple form, where two horseshoe magnets were interconnected with soft iron wire and two bars of zinc placed between the legs of the magnets. Roy found that he got an output of 8 volts using just two 4-inch magnets with 1-inch square legs and zinc bars of similar size. The physical orientation of the device is very important as current is collected if the open ends of the magnets are pointing in a North - South direction and no current is produced if they are positioned in the East - West direction. The first arrangement is shown in the following diagram:

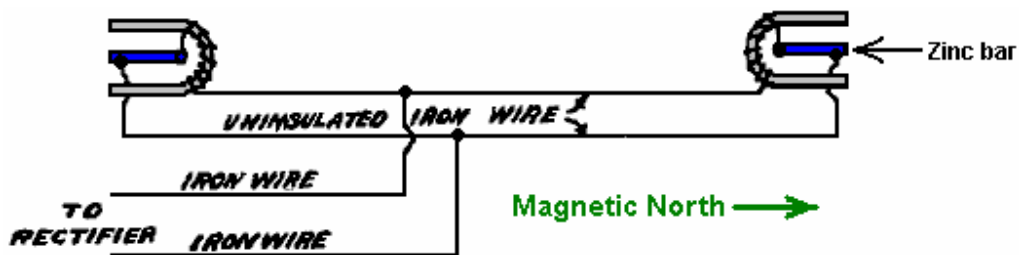

Roy developed his system further and found that while it works indoors, it does perform better if located outdoors and raised to a height of fifty or sixty feet. However, that is by no means essential, and the output power and voltage can be increased by increasing the number of collector units. Roy developed these to produce the style shown here:

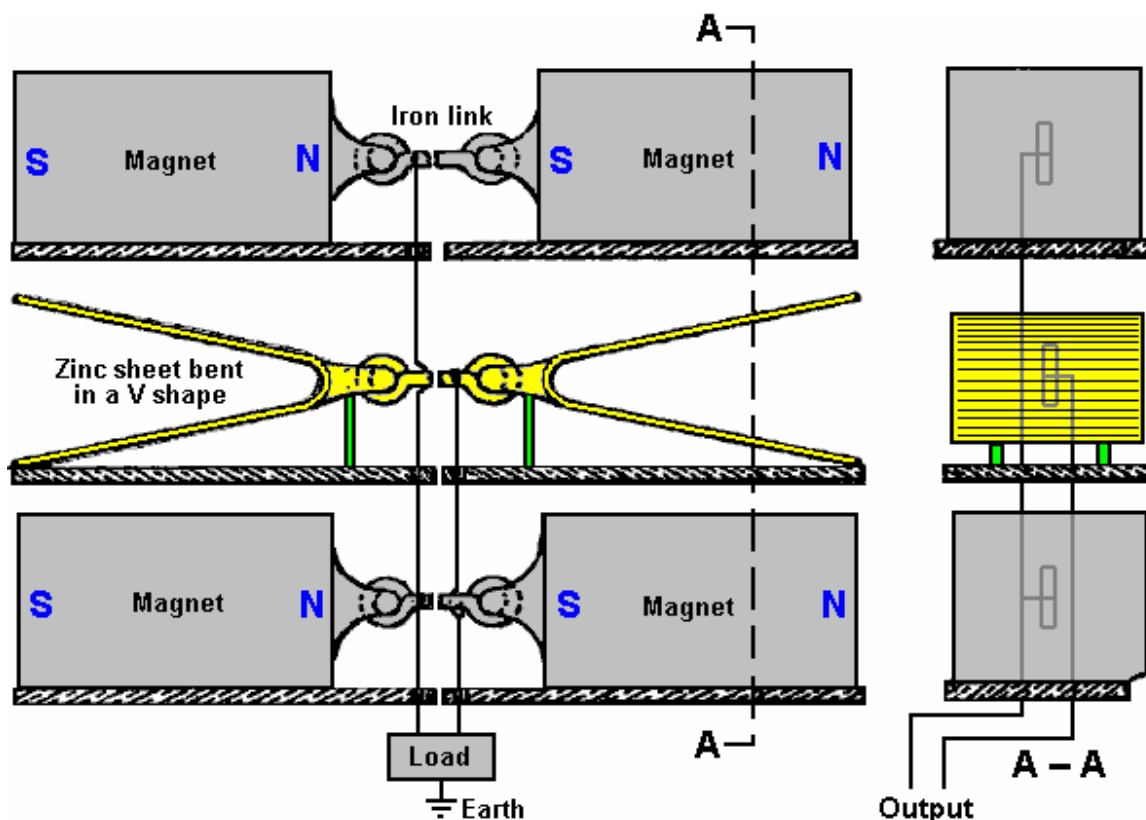

The zinc acts more effectively if installed as sheets bent into a V shape. The magnets and zinc sheets can be stacked vertically and/or horizontally and the greater the number used, the greater the electrical output. A good earth connection is recommended and presumably, the average cold water pipe of any house provides a more than adequate earth connection which is convenient to use.

## 2. Energy can be captured via a strong and very brief magnetic pulse

Ed Gray snr/Creative Science, Robert Adams, John Bedini, Bob Teal

Edwin V. Gray Snr.



Edwin Gray worked as a US Air Force engineer and machine-shop technician. Having discussed the matter with an associate of Nikola Tesla, in 1958 Ed discovered that the magnetic field generated by the very fast discharge of a high voltage source could pick up additional energy. (This was not actually a new discovery as Nicola Tesla had already burnt out a power station when he tried this on a large scale). In the seventies, Edwin built a device to capture this extra energy. The rapid, abrupt discharge was produced by generating a spark, and the pick-up was achieved by two copper cylinders surrounding the conductor which carried the spark current.

He used the extra power to drive opposing electromagnets in an 80 horsepower electric pulse motor. His patents show the pulses passing through the driving coils of the motor, charging a second battery via a current-limiting capacitor. Running this powerful motor was essentially free as the battery used to generate the spark voltage was switched periodically with the battery under charge. The result is a powerful motor which needs no fuel to run. He received US Patent No 3,890,548 in June 1975 and Patent No 4,661,747 in April 1987. A full and detailed description of how Ed Gray's system works is given in Peter Lindemann's book "The Free Energy Secrets of Cold Electricity" which is available via [www.free-energy.ws](http://www.free-energy.ws). I highly recommend that you read this book.

Ed Gray's circuit is:

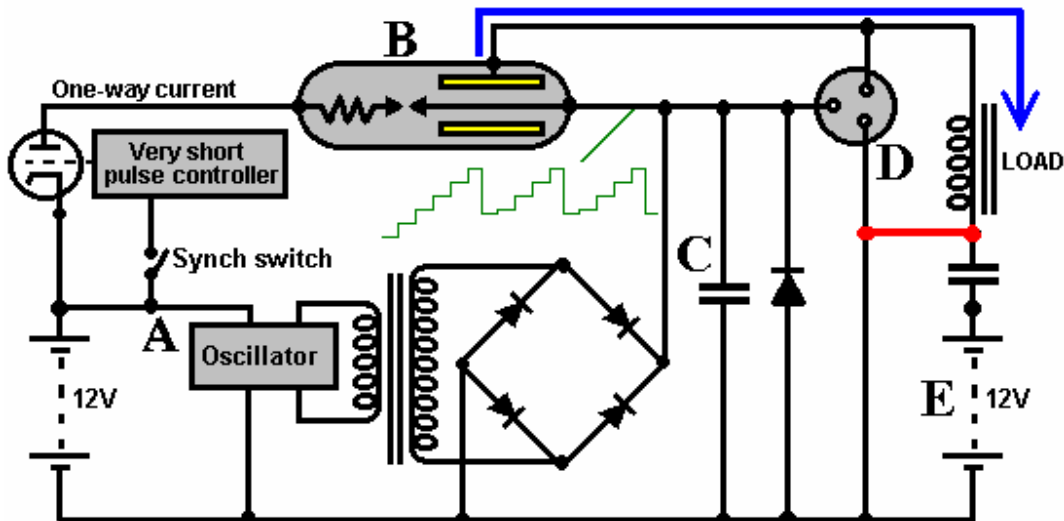

Three of these circuits were used to drive each engine. The operation is as follows:

1. The battery at 'A' provides the operating current for the circuit, powering the oscillator.

2. The oscillator drives the transformer which steps the 12V pulses up to 3000V.
3. The 4000 volt 2 Farad capacitor at 'C' builds up a high voltage in steps with each oscillator pulse (the synch switch being open)
4. The motor synchronisation switch closes due to the rotation of the engine.
5. This causes the pulse controller to switch the triode valve on for a very short time - probably 80 microseconds or so, completing the circuit from the battery, placing a high voltage across the spark gap at 'B'
6. The capacitor at 'C' starts to discharge, creating a spark in the tube at 'B'. The pulse duration is kept exceptionally short by the electronic pulse timer circuit which cuts the path off very abruptly. To generate the Radiant Energy wave, it is essential to produce a very short, sharp positive DC pulse which never goes negative. The capacitor does not discharge fully as there is not enough time for it to do so.
7. Some of the Radiant Energy wave caused by this pulse, is picked up by copper cylinders placed around the electrode rod. The copper cylinders act more effectively if they are drilled with a matrix of holes. The Radiant Energy is fed to the load coils at 'D' as shown by the blue current flow path. It should be noted that this electrical energy has been created by the Radiant Energy waves passing through the copper cylinders. This power is at least 100 times greater than the power taken from the battery to create the spark and this current can easily be 1,000 amps. It should be stressed that this power is **not** coming from the battery as the battery power is used solely to create the spark.
8. The load coils power the motor forwards, or if the circuit is being used for other purposes, powers transformers, bulbs, etc. usually via an air-cored, heavy duty transformer.
9. The patents show the load coil pulse being fed on to a second battery at 'E' via a current-limiting capacitor, thus charging that battery. However, Ed stopped doing this in favour of using a standard car charging system. The red by-pass link indicates that the capacitor and battery would normally be omitted. With the capacitor in place, the current pulses into the battery were in the 60 to 120 amps range, some six thousand times per second. Even with the capacitor in place, the current pulses are likely to damage the battery. Because the return current was fed to +12 volts rather than 0 volts, it was referred to as "splitting the positive" and it helped to ensure that the pulses never went negative. However, to save the battery under charge from being damaged, Ed switched to charging the spare battery using a conventional vehicle alternator.
10. The spark-gap device at 'D' provides protection should the voltage at 'B' become excessive. It should be remarked that the graphite slab placed in the copper rod electrode has a low resistance and so is not there to limit the current. The choice of material is important as graphite is thought to be favoured by Radiant Energy flows, so its inclusion is probably to promote the generation of the Radiant Energy waves.

Ed used three of these power conversion tubes for each of his engines. Each tube provides one drive pulse during each rotation of the engine drive shaft. This proved to be a highly effective system, providing a large amount of engine power without any need for external charging of the batteries. The engine design includes an ingenious method of power control where the pulse-timing mechanism is physically moved by the throttle pedal of the vehicle. This retards or advances the driving pulses to the rotor, relative to its alignment with the stator magnets. This has a dramatic effect on the mechanical output power and is an effective throttle arrangement in spite of being such a simple mechanism.

There are almost no criticisms to be made of this motor, except perhaps, that because it uses rotating electromagnets, there have to be brushes to feed the current to those electromagnets. A timer circuit can be used to swap the batteries over every few minutes without any manual intervention.

An excellent web site for information on Ed Gray is: <http://www.free-energy.cc/gray.html>

At the time of writing, a very long but very informative video of a lecture by Dr Peter Lindemann on the secret of Cold Electricity with special reference to Ed Gray's system can be found at:  
<http://video.google.com/videoplay?docid=6531378517026122577&q=Cold+Electricity>

Also, Norman Wootan, Ed Gray's close friend, has acquired several of Ed's prototype motors. He displays them and their internal components in a lecture, a video of which, at this time, can be found at:  
<http://video.google.com/videoplay?docid=5295639549070622452&q=Cold+Electricity>

The construction of the pick-up tube is not particularly difficult. It is comprised of a teflon (plastic) cylinder of about 80 mm diameter with teflon plates at each end, grooved to hold the pick-up cylinders in place. A pair of 12 mm diameter copper rods are positioned down the centre of the cylinder and provided with a means to adjust

the gap between them where they meet. The rod ends form the spark gap and these ends are plated with silver. One rod has a graphite block inserted in it, using a push-fit connection into slots cut in the bar.

The two or three cylinder shells which pick up the Radiant Energy, are constructed from copper sheet. The gap between the outside of one cylinder and the inside of the surrounding cylinder is about 6 mm. These cylinders are more effective if they have a matrix of holes drilled in them. They are connected together electrically and the connection is led out through the teflon casing to feed the load circuit. The cylinder contains air rather than a vacuum or an inert gas. The copper cylinders are held in place by push-fit supports, one set positioned between the outside of the smaller cylinder and the inside of the larger cylinder. The second set are placed between the outside of the larger cylinder and the inside of the housing tube:

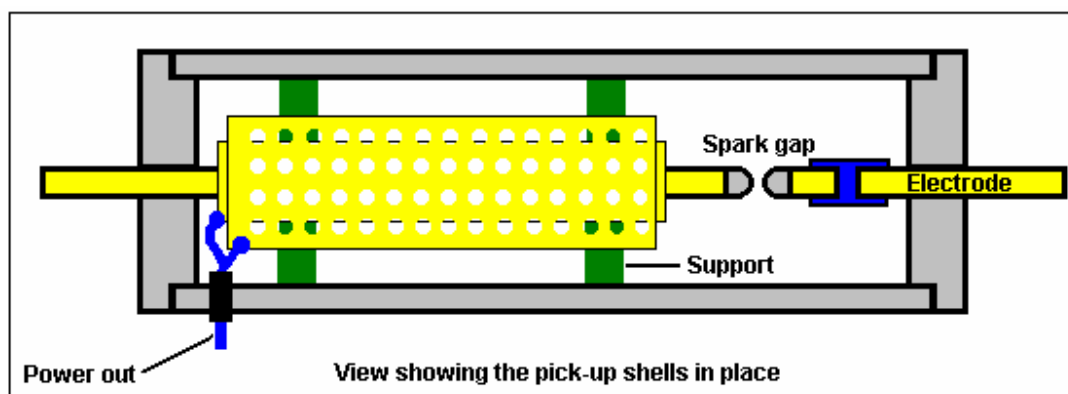
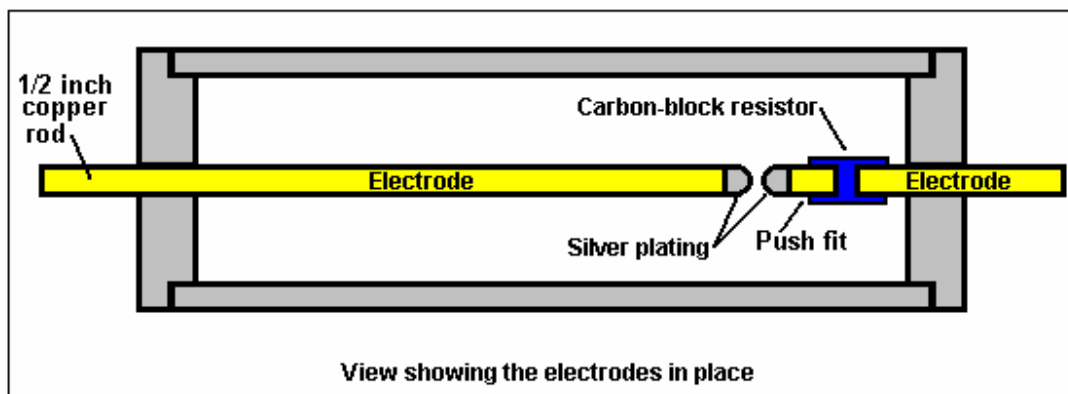
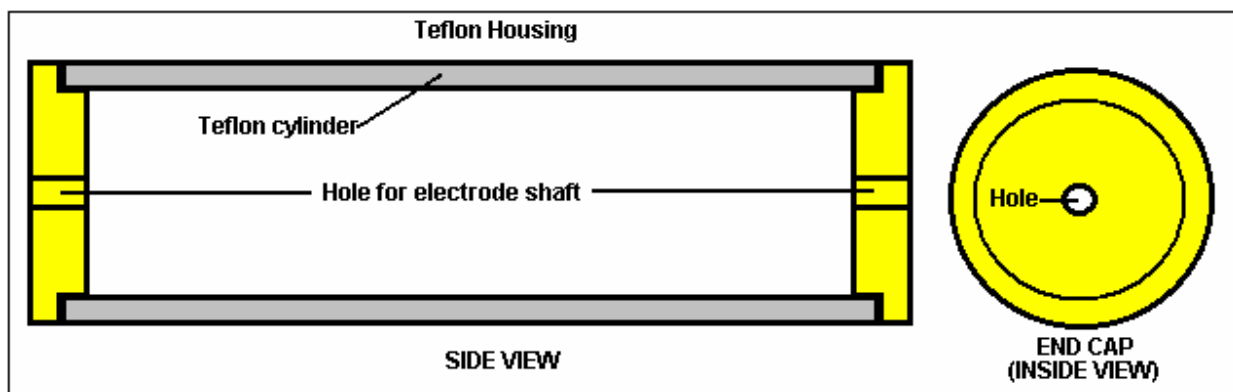

The power tube is constructed this way because the Radiant Energy wave generated by the sharp pulse of current through the electrodes, radiates out at right angles to the electrodes.

These details were provided to John Bedini by Ed Gray during John's visits in 1979, 1982 and 1984. John recorded them on his sketches of the system on each occasion. He kept them confidential for nineteen years, but then, when all of the people involved were dead, he passed the information to Peter Lindemann who had already deduced almost all of the details from the patent information and some unpublished photographs. Peter then published the exact details in the third edition of his book "The Free Energy Secrets of Cold Electricity".

Peter points out that Ed Gray's power conversion tube circuit is effectively a copy of Nikola Tesla's circuit for doing the same thing:

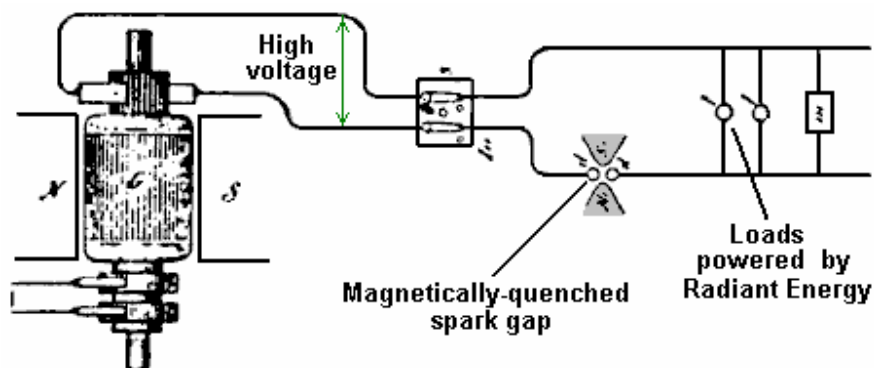

This was disclosed by Tesla in his 'Philadelphia and St Louis' lecture in 1893 and shows how loads can be powered when a high voltage source is pulsed by a magnetically-quenched sparks - this creates DC pulses of very short duration. More details about this are given in the accompanying document in this set entitled "D8.pdf" ('Devices' Part 8).

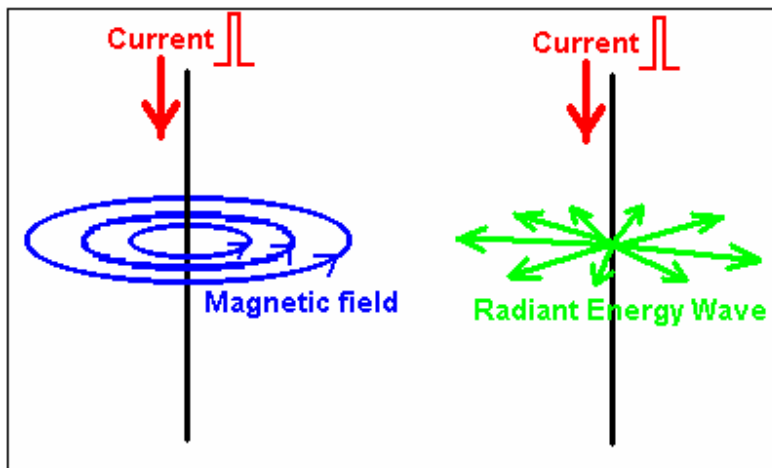

The diagram above, illustrates the difference between the Magnetic field generated around a conductor fed with a pulse of Direct Current and the Radiant Energy waves created by that pulse. If a sharp current pulse is driven down a vertical wire, it causes two different types of field. The first field is magnetic, where the lines of magnetic force rotate around the wire. These lines are horizontal, and rotate clockwise when viewed from above. The magnetic field remains as long as the current flows down the wire.

The second field is the Radiant Energy wave. This wave will only occur if the current pulse is in one direction, i.e. it will not occur if the wire is fed with alternating current. The wave radiates out horizontally from the vertical wire in every direction in the form of a shock wave. It is a one-off event and does not repeat if the current in the wire is maintained. The Radiant Energy which can be picked up from this wave is in excess of 100 times more than the energy of the current in the vertical wire. This is the energy which Edwin Gray's tube was designed to collect. Consequently, his tubes are fed with a train of high-intensity, short-duration, DC pulses to generate repeated waves of Radiant Energy. It is the pick-up of this excess energy which allows his motors to run without the need for the batteries to be charged by any conventional source of current.

The Radiant energy wave is not restricted to a single plane as shown in the diagram above, which is intended to indicate the difference between the electromagnetic field circling around the wire, and the Radiant Energy field which radiates away from the wire. Both of these fields occur at all points along the full length of the wire as shown here:

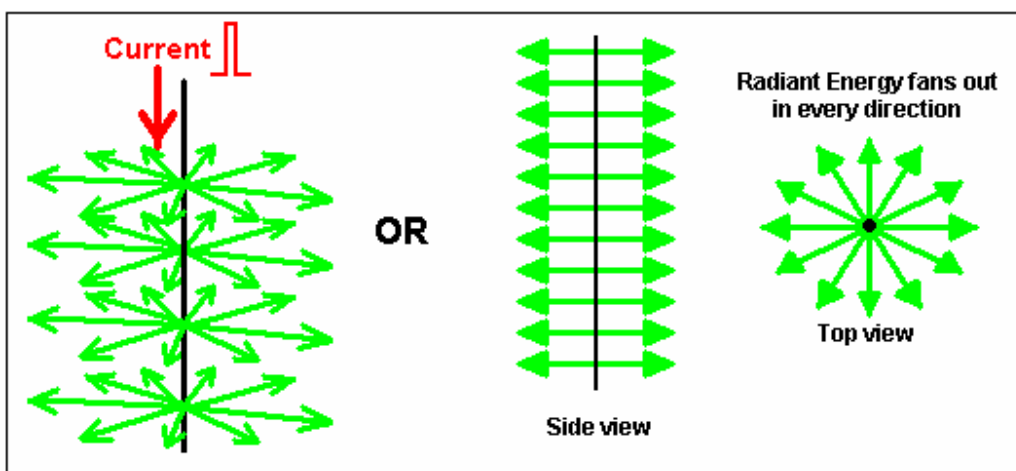

Radiant Energy, when converted to electrical power, produces a different kind of electrical power to that produced by batteries and by the mains supply. Power a motor with conventional electricity and it gets hot under load. Power the same motor by Radiant Energy electricity and under load the motor gets cold. Really overload it by stalling it and the motor housing is likely to be covered with frost. That is why this form of electricity is referred to as "cold electricity".

If a lightbulb powered by conventional electricity is placed in water and you put your hand in the water, then you will almost certainly receive a severe electrical shock which may even kill you. Power the same lightbulb with Radiant Energy electricity and place it in water. The bulb will continue to shine and putting your hand in the water will have no ill effects at all, quite the reverse in fact, as that electricity has healing properties

Here is a cross-section of Ed Gray's motor. The electromagnets marked "1" are powered by the first capacitor charging circuit, those marked "2" are powered via the second charging circuit and those marked "3" are powered by the third charging circuit. The motor is driven by a brief pulse of high current being applied to the rotor electromagnets and one the numbered sets of fixed ("stator") electromagnets. This is done so that they repulse each other and the timing is arranged so that the pulse occurs just after the rotor electromagnets have passed over the fixed electromagnets. This way, the rotor gets a strong rotary push nine times during each revolution - or it would do were it not for the extra electromagnets shown in blue in the diagram. Ed Gray opted for a more complicated switching arrangement which gives 27 drive pulses per revolution by using the extra electromagnets and nine electronic circuit copies but this is not important for understanding the operation of his motor. He also designed an ingenious speed control where the electromagnet spark gaps are physically moved to advance the pulse timing (which slows the motor) or retard the pulse timing (which speeds the motor up).

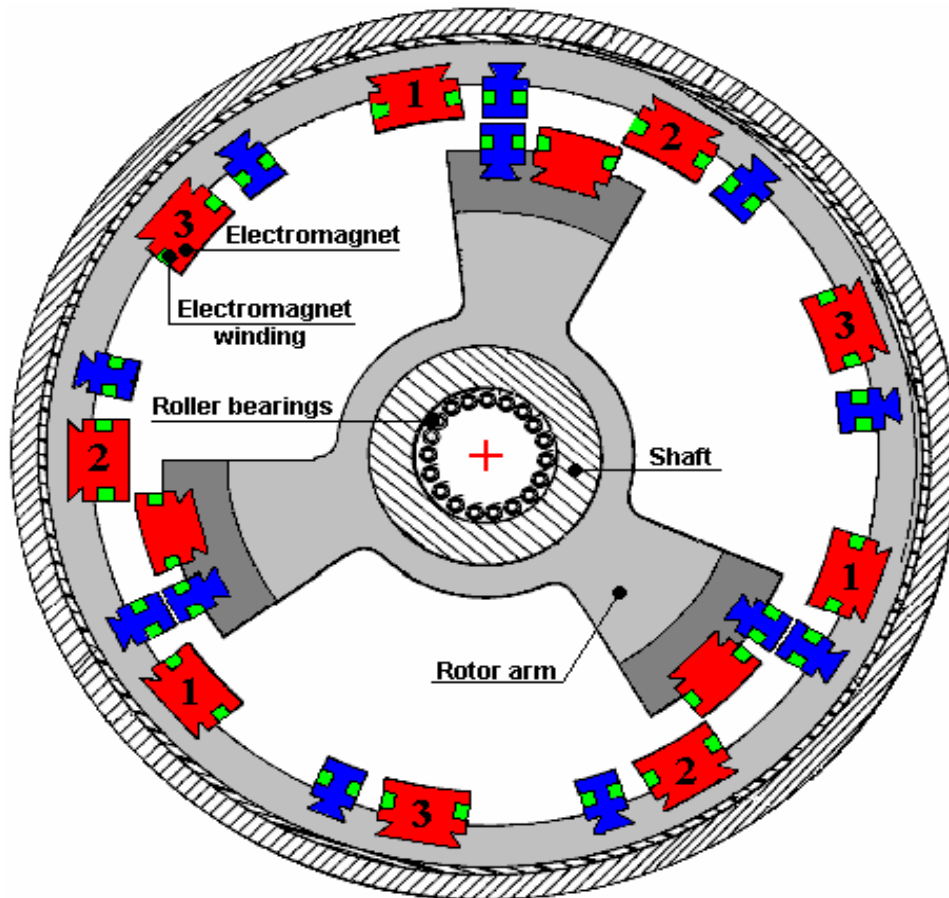

It may be a little difficult to visualise the electromagnets from the above diagram, but consider them to be about 200 mm (6") long, running into the screen, with a wire wound around them, lying in a slot which runs all round the whole of the four sides. The advantage of using an electromagnet is that the power is controlled by the current running through the winding and is not limited by what permanent magnets are available at the time. The power of an electromagnet increases with the number of turns, the strength of the current pulse and the core material (air, soft iron, laminated iron,...). The disadvantage is having to pass current to the moving electromagnets which is done by brushes which generates noise and wear - but neither excessively. One detail which does not show in the patent is the fact that the electromagnet laminations were machined with a fifteen degree angle across their width. This created a sloping face on both the stator and rotor magnets, with the slope facing the direction of rotation. When the magnets fired, the magnet faces are parallel but not facing towards the centre of the shaft. This gives the rotor extra torque without needing extra current.

Conclusion: Edwin Gray's motor has a very clever mechanical throttle which operates by rotating the pulsing coils slightly. It is very efficient and may produce more output than its electrical input, but the main source of power is his power conversion tube which taps the Radiant Energy field and supplies the energy to the motor. It should be stressed that the motor, clever and all as it is, is not a necessary part of Ed's invention as the power conversion tube has been demonstrated on its own, powering lights and other loads via an air-cored (high frequency) transformer wound on a four-inch diameter plastic pipe, using very heavy duty wire such as is used for vehicle spark plugs.

## Alfred Hubbard.



In 1920 Alfred Hubbard demonstrated his 'Atmospheric Power Generator' which was said to have an output power of some three times greater than the input power. It is difficult to determine the exact details of its construction, but the best information to hand suggests the following:

It consisted of one tall central iron-cored 'primary' coil 15 inches high. The core was made from 16 iron rods and the winding made of 43 turns of cable. The cable had 7 cores each of 0.09" diameter, forming a bundle 0.204" in diameter inside the insulation which had an outside diameter of 0.34" which is American Wire Gauge Size 4 wire.

Placed around the central coil were 8 'secondary' coils wound on low-carbon steel fence pipe of 2" inner diameter and approximately 2.25" outer diameter (57 mm), 15 inches high. The windings were also 43 turns of AWG No 4 wire and the coils were wired with the bottom of each coil connected to the top of the adjacent coil, i.e. the secondary coils were wired in series. The secondary coils touch each other tangentially and they also touch the central primary winding tangentially.

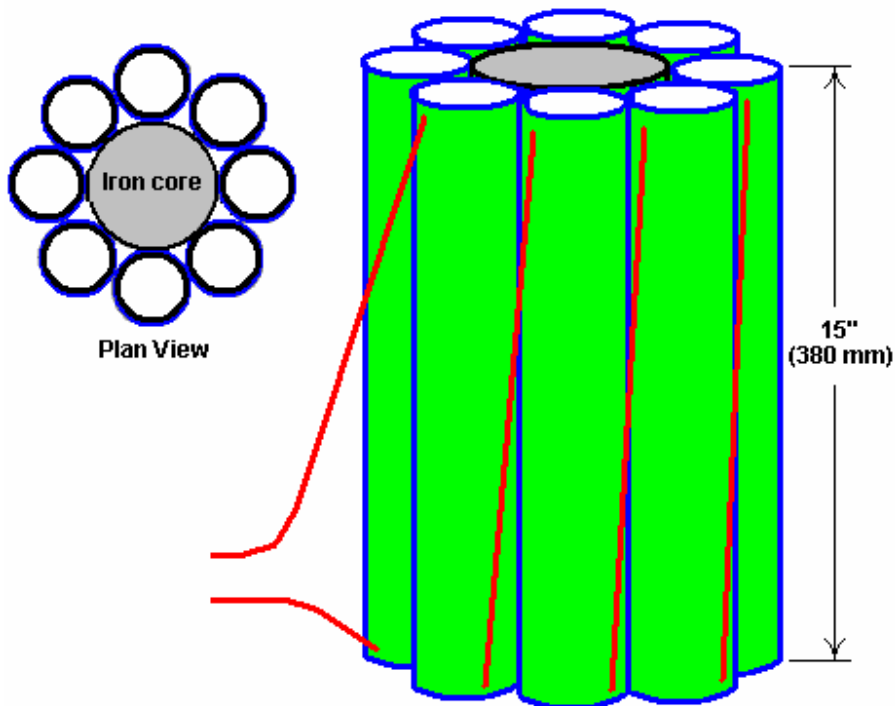

The generator was initially demonstrated powering an 18-foot boat with a 35 horsepower electric motor, around Portage Bay on Lake Union, Seattle at eight to ten knots, starting from the Seattle Yacht Club wharf. It appears that the wires should have been larger diameter as they started to overheat quite quickly. Dozens of people

witnessed this demonstration and it was reported in the local Seattle press. Alfred is reported to have referred to the secondary windings as “electromagnets” each having both primary and secondary windings of copper wire. Details of the device are presented in Joseph Cater’s book “Awesome Force” which attempts to explain the theory of its operation.

The circuit looks deceptively simple, with the DC input being converted to a rapid train of very short duration pulses, stepped up in voltage and fed to the primary winding. The output is passed through a step-down transformer and was said to be 280 Amps at 125 Volts:

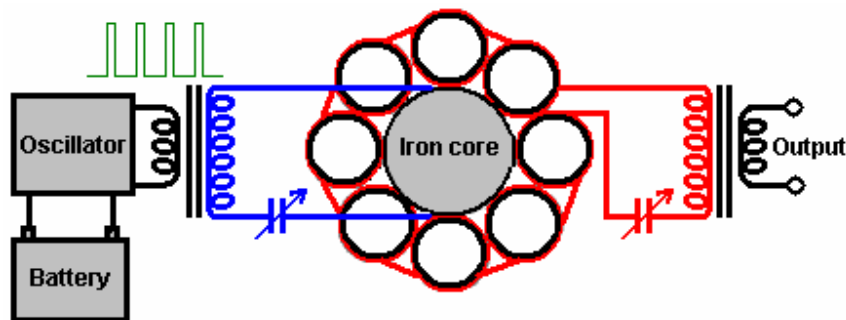

The variable capacitors shown are used to tune the input and output circuits to their resonant frequencies. There appears to be similarities between this circuit and the circuitry used by Edwin Gray when he was using his power tube to drive mains light bulbs and other standard electrical equipment. Edwin used air-cored transformer windings of very heavy-duty wire, to drive the loads and while Alfred does have steel formers for the secondary coils, they are mainly air-core, unlike his primary coil. Edwin and Nikola Tesla were tapping the same source of power, and since Alfred Hubbard worked with Tesla for a short period, it seems likely that his transformer is based on the same techniques that Tesla used so successfully.

It may well be that Alfred’s circuitry was actually constructed more like Tesla’s circuitry for his unique coils. It might have been like this:

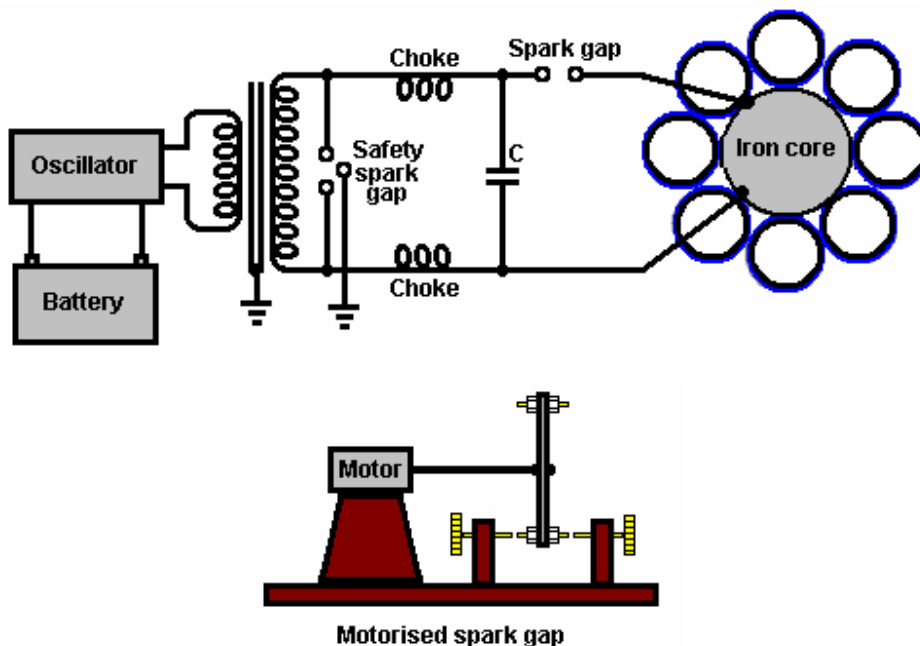

Alfred’s association with Tesla raises some interesting points. Firstly, Tesla was aware that to generate Radiant Energy waves of the type that Edwin Gray trapped so successfully, ideally, uni-directional pulses of very short

duration (1 millisecond or less) were needed. The best way to generate these is using a spark, so it is distinctly possible that Alfred's oscillator contained a spark generator. Secondly, Tesla was aware that a serially-connected bi-filar wound coil is a very effective device for collecting Radiant Energy. Might it be possible that the information on how the secondary coils were wound and connected is not quite correct, and that while the coils were connected in series, they were bifilar-wound, possibly, but not necessarily, wound as shown here:

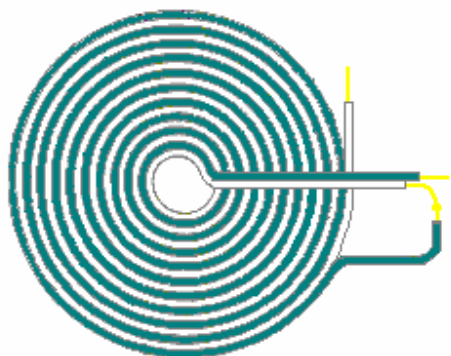
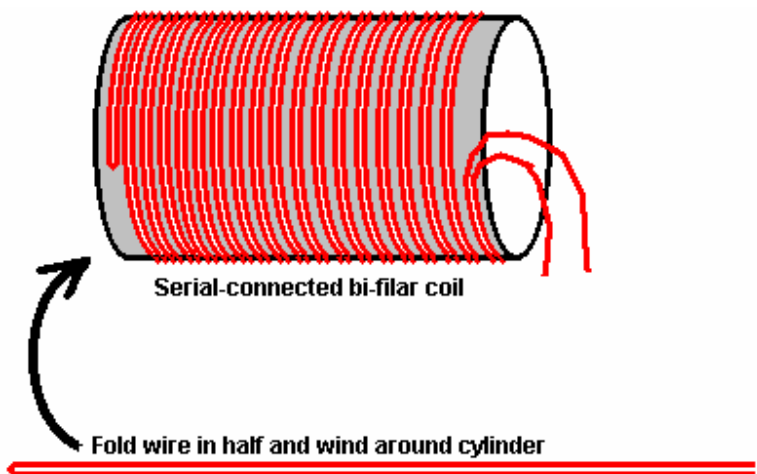

Alternative flat 'pancake' coil winding method patented by Nikola Tesla

In fact, it seems much more likely that there were separate inner bi-filar windings connected in series while the outer bi-filar windings were also connected in series, especially since, it was reported that the device had four wires coming out of it. This strongly suggests that the bi-filar series-connected 'secondary' windings were connected internally to form the final circuit and that the four wires were one pair for the primary winding and one pair for the serially-connected pickup set of sixteen windings:

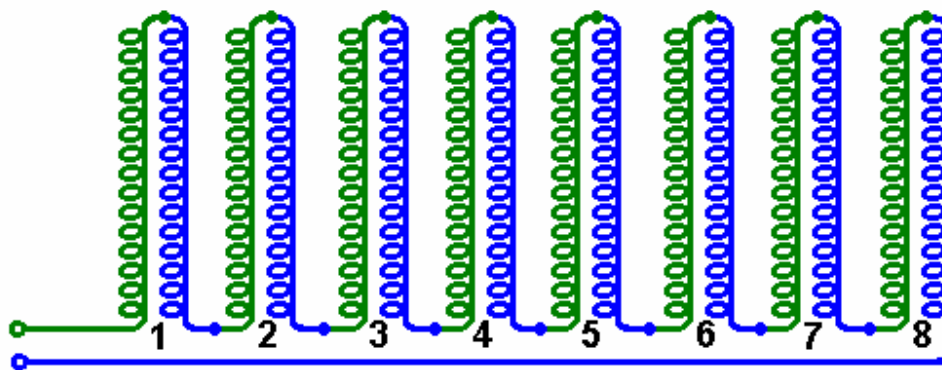

Possible series-connected bi-filar connection method for Hubbard's "secondary" coils

The device was examined and tested fully by Father William Smith, professor of physics at Seattle College. He was quoted as saying "I unhesitatingly say that Hubbard's invention is destined to take the place of existing power generators". While this indicates that Professor Smith's examination and tests showed that the device worked extremely well, he clearly was not aware of the marketplace opposition to any commercial form of free-energy device.

It has been suggested that the core of the device was packed with radio-active material (probably radium) and that an outer steel cylinder was placed around the device to absorb excess radiation. If that was so, the amount of material would have been very minor, and used only to ionise the air around the coils to improve the energy pick up. Any radio-active material used would have been similar to the 'luminous' paint which used to be applied to the hands of alarm clocks, and consequently, fairly harmless.

It is said that **Paul Brown** attempted to reproduce Hubbard's device with a certain degree of success. He was attempting to build a 100 watt device but found that his device was unstable, giving surges of output power of the order of kilowatts. He managed to stabilise his device with an output of 5 watts and to gain funds for further development, he obtained US patent 4,835,433 on 30th May 1989. He described the device as an "Apparatus for Direct Conversion of Radioactive Decay Energy to Electrical Energy" so as to get it patented. He remarked that only one in a hundred people spotted that fact that the five watt output was 1000 times greater than could actually be got from the very weak 1 curie radioactive material in the device.

The diagrams from the patent which are displayed here, show that Paul's patent was for the Hubbard device.

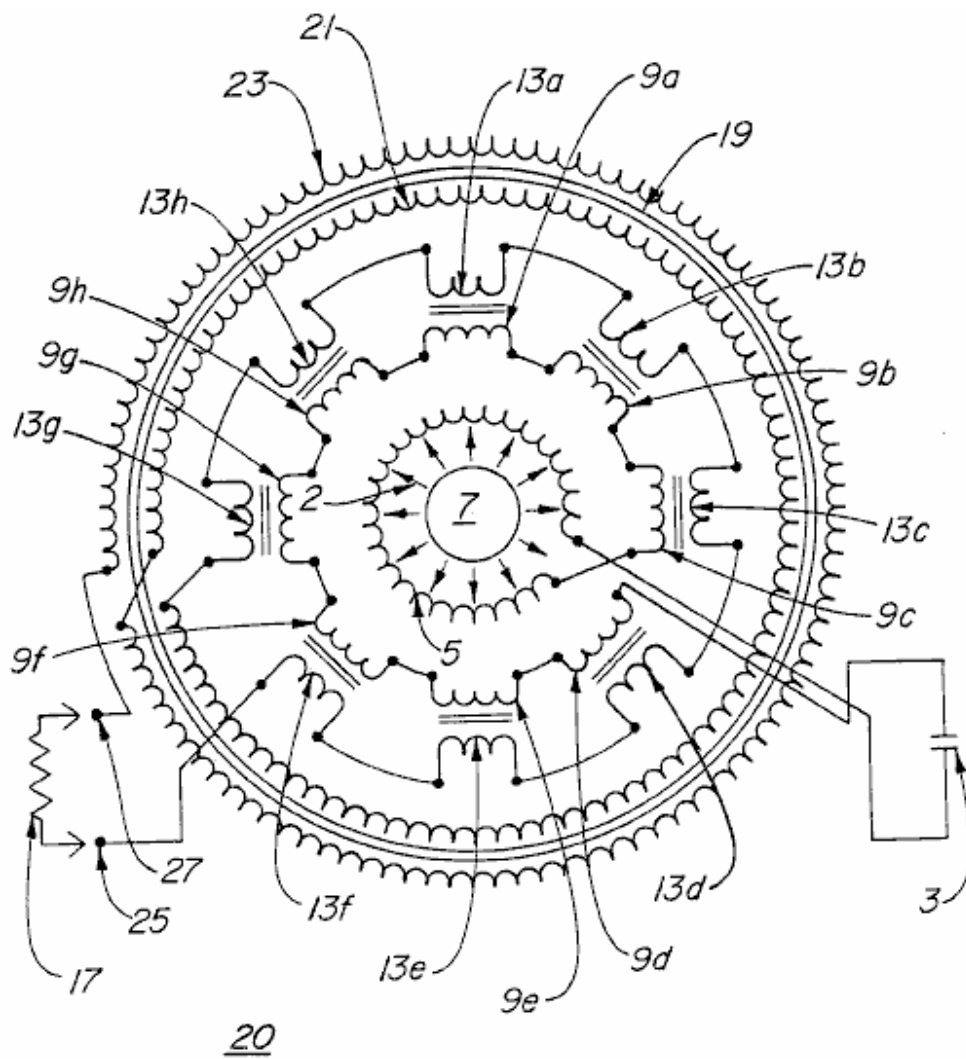
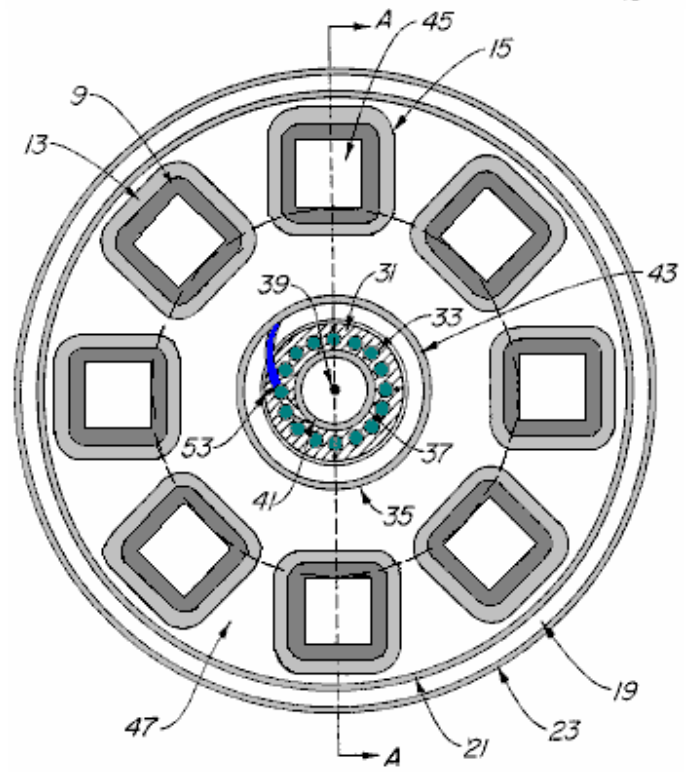
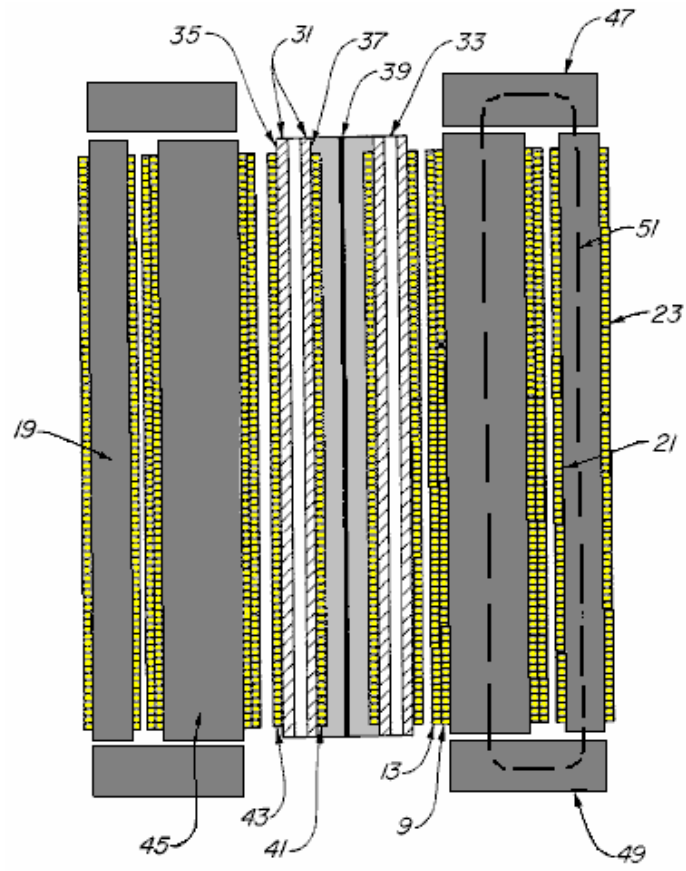

Fig. 2



Here is a direct quotation from Paul: "In 1987 we decided it was time to let the world know what we were working on and the results we were getting. It was a proud time for me. I thought we were doing the right thing. But this was the real beginning of the worst. Since that February 1987, I or my company have been persecuted by the State Dept. of Health; then the Idaho Dept. of Finance filed a complaint against the company and myself; my license for handling radioactive materials was then suspended for 6 months; I began to receive threats (i.e. 'we will bulldoze your home with your family in it'); then the investigation by the Oregon Dept. of Finance; then the tax man; then the Securities and Exchange Commission; my wife was assaulted; I lost control of my company; my home has been robbed three times and vandalized on four other occasions; twice now I have been accused of drug manufacturing; I lost my home; most recently my mother's car was pipe bombed. With each hardship I strive harder toward successful development of the technologies under my endeavor. But it only seems to get worse.

Someone once said, 'Paranoia is only a heightened sense of awareness.' He was right! It is hard for the average guy to comprehend these disasters happening to select people. I am here to tell you it is not coincidence. I now understand why some inventors drop out from society.

My advice to you is keep a low profile until you have completed your endeavor; be selective in choosing your business partners; protect yourself and your family; know that the nightmare stories are true"

On 7th April 2001, Paul Brown who liked to race his RX7 was talked into having a drag race by a stranger at 2:00 am on a Sunday morning. The car rolled 5 times and Paul died.

\*\*\*\*\*

Other documents in this set can be downloaded free from [www.web-space.tv/free-energy](http://www.web-space.tv/free-energy) (needs the browser's Refresh button to get past a German-language advertisement page to reach the site).